

# PLAN PREPARATION AND PROCEDURE MANUAL

**NOTE:**

*This document pursuant to section 8 of The Land Surveys Regulations, constitutes instructions from the Controller of Surveys for the preparation and examination of plans. Reference should still be made to the various Acts and Regulations pertaining to specific situations, which may or may not be included in this document.*

## Revision History

Version #	Revision Date	Description of Changes	Page Number
1	October 4, 2014	Initial Manual – compiled from existing documents and PSO requirements	--
2	April 24, 2020	Name of Manual changed from Drafting Requirements for the Preparation of Plans to Plan Preparation and Procedure Manual	1
2	April 24, 2020	Plan orientation – information readable from bottom right hand corner, Plan Format, item 5	6
2	April 24, 2020	Clarification - removal of subdivision logo from plan, Plan Format, item 8	6
2	April 24, 2020	Plan scales – addition of 1:10,000 scale, Plan Format, item 9	6
2	April 24, 2020	Plan abbreviation listing added, Plan Format, item 16	8
2	April 24, 2020	Text sizes – from standard to minimum, Plan Format, item 17	9
2	April 24, 2020	Certificate of Surveyor Clarification, Plan Format, item 23	10
2	April 24, 2020	Monument information & Illegible Monuments – Survey company ID not required, Monuments, items 2 a) & 2 b)	11
2	April 24, 2020	Status of existing monuments, Monuments, item 12	12
2	April 24, 2020	Monuments found at corners of Metes & Bounds, item 18	13
2	April 24, 2020	Showing All Monuments, item 19	13
2	April 24, 2020	Cut Cross Information, Monuments, item 14	14

2	April 24, 2020	Unable to plant a monument clarification, Monuments, item 17	14
2	April 24, 2020	Angle to Lot Line Clarification, Curve Information, item 1	15
2	April 24, 2020	Change from 3 IPs to 4 IPs, Curve Information, Item 2	15
2	April 24, 2020	Water as an Implied Exception, Natural Boundaries, items 4, 5, 6, & 7, Clarification Table, & Diagrams	24
2	April 24, 2020	Consolidation Clarifications, Miscellaneous, items 5, 6, 7, 8, 9, 10 & 11	29
2	April 24, 2020	Right of Way Posting Clarification, Miscellaneous, item 13 & 14	30
2	April 24, 2020	Utility Right of Way Clarification, Miscellaneous, item 21	31
2	April 24, 2020	Parallel Right of Way Clarification, Miscellaneous, item 23	31
2	April 24, 2020	Deflection Angle Clarification, Miscellaneous, item 31	33
2	April 24, 2020	Primary Re-establishment Clarifications, Miscellaneous, items 33, 34, & 35	34
2	April 24, 2020	Subdivisions in Provincial Parks Miscellaneous, item 37	35
2	April 24, 2020	Secondary Survey Intersection Clarification, Miscellaneous, item 38	35
2	April 24, 2020	Labelling Correction Lines, Miscellaneous, item 39	35
2	April 24, 2020	5 – sided Quarter, Miscellaneous, item 40	35
3	August 11, 2021	Monuments at all corners, Monuments, items 4	11

3	August 11, 2021	Examples of Plan Notations Diagrams, Monuments	13
3	August 11, 2021	FIP vs. Found Evidence, Monuments, item 13	13
3	August 11, 2021	Deeply Recessed Monuments, Monuments, item 20	14
3	August 11, 2021	Change from 4 IPs to 3 IPs, Curve Information, Item 2	15
3	August 11, 2021	Intersecting curves with a surveyed line diagrams, Curve Information, item 3(iii), a, b, c, & d	19
3	August 11, 2021	Areas on Supplemental township plats, Area, item 5	21
3	August 11, 2021	Natural Boundary Clarification Table, Diagram, Natural Boundaries, table and diagram 5	25 & 26
3	August 11, 2021	Feature Plans and Water, Natural Boundaries, item 9 & 10	27 & 28
3	August 11, 2021	Widths of Right of Way Plans, Miscellaneous, item 18	31
3	August 11, 2021	Boundary relation, Miscellaneous, item 32	34
3	August 11, 2021	Primary Monument Re-establishment, Miscellaneous, item 36	34

As of August 11<sup>th</sup>, 2021, the above item numbers and page numbers have not been updated with the current manual revision.

<b>Version #</b>	<b>Revision Date</b>	<b>Description of Changes</b>	<b>Page Number</b>
4	April 4, 2023	Overview, Statement revised	9
4	April 4, 2023	Revised reference to Natural Boundaries Section, Plan Format, Item 12c	10
4	April 4, 2023	Added Est, Pt, and Sm to approved abbreviations list, Plan Format, Item 16	11
4	April 4, 2023	Changed minimum lettering size of Survey Information and Plan Numbers, Plan Format, item 17	12
4	April 4, 2023	Title blocks for re-establishment plans in rural and urban areas, Plan Format, item 22 a & b	13
4	April 4, 2023	Added Lost Monument, Established Point or Established Point to approved symbols, Monuments, item 1	14
4	April 4, 2023	Illegible monuments, Monuments, item 2c	14
4	April 4, 2023	Markings of right of way monuments, Monuments, item 2d	14
4	April 4, 2023	Field Evidence Sketches, Monuments, item 3	14
4	April 4, 2023	Reference monuments only apply in rural areas, Monuments, item 4	15
4	April 4, 2023	Diagram - Removing Monuments, Monuments, item 7	15
4	April 4, 2023	How to handle offline secondary monuments and associated diagrams, Monuments, item 8	16
4	April 4, 2023	Re-establishment of a primary corner from road monuments revised, Monuments, item 9	16
4	April 4, 2023	Showing all monuments revised, Monuments, item 14	17

4	April 4, 2023	New witness monuments requirements, Monuments, item 16	17
4	April 4, 2023	Plan Notations Diagrams added, Monuments	18 & 19
4	April 4, 2023	FIP vs. Found Evidence clarification, Monuments, item 17	19
4	April 4, 2023	When a monument is required clarification, Monuments, item 21	20
4	April 4, 2023	Deteriorated monuments, Monuments, item 22	20
4	April 4, 2023	Confirmation of monuments, Monuments, item 23	20
4	April 4, 2023	Diagram added, Curve Information, item 1	21
4	April 4, 2023	Curve Note revised – 3 monuments required, Curve Information	22
4	April 4, 2023	Legal subdivision designation clarification, Parcel Designations, item 3	27
4	April 4, 2023	Implied Exception Note, Natural Boundaries	32
4	April 4, 2023	Cannot define a boundary by centerline of creek, Natural Boundaries, item 9	32
4	April 4, 2023	Feature plans with receded water - diagram added, Natural Boundaries, item 10	34
4	April 4, 2023	Municipal boundaries relating to natural boundaries, Miscellaneous, item 5	35
4	April 4, 2023	Consolidations of titled and abstract parcels clarification, Miscellaneous, item 6	36
4	April 4, 2023	Right of Ways – Diagrams and Clarification, Miscellaneous, item 14	37

4	April 4, 2023	Right of Ways – Unsurveyed Provincial Lands, Miscellaneous, item 15	37
4	April 4, 2023	Posting requirements on right of ways using centerline and diagram, Miscellaneous, item 16d	38
4	April 4, 2023	Tie line not required for right of ways using primary lines, Miscellaneous, item 17	38
4	April 4, 2023	Right of way utilizing an existing posted limit, Miscellaneous, item 18	38
4	April 4, 2023	Right of way intersection posting, Miscellaneous item 20	38
4	April 4, 2023	Angular & linear measurements at each new boundary, Miscellaneous, item 32	40
4	April 4, 2023	Block corner re-establishment, Miscellaneous, item 41	43
4	April 4, 2023	Upgrading small iron posts to standards iron posts in urban block surveys, Miscellaneous, item 42	43
4	April 4, 2023	The term “Tie Only” and its use, Miscellaneous, item 47	44
4	April 4, 2023	5-sided quarter clarification, items 48 & 49	45

As of April 4<sup>th</sup>, 2023, the above item numbers and page numbers have not been updated with the current manual revision.

5	May 21, 2025	Plan sizes - Plan Submission Online max file size, Plan Format, item 1	12
5	May 21, 2025	Title Block - legal land description includes quarter section, Plan Format, item 6 a	12
5	May 21, 2025	Title Block - dual type and dual purpose plans, Plan Format, item 6 b	12
5	May 21, 2025	Northern Plans, Latitude and Longitude, Plan Format, item 21 a	16
5	May 21, 2025	Title Block - Re-establishment in an urban area, Plan Format, item 22 b	16
5	May 21, 2025	Certificate of Surveyor, Plan Format, item 24	16
5	May 21, 2025	Field Evidence Sketches – Monuments, item 3	17
5	May 21, 2025	Monuments at all corners, Monuments, item 4	18
5	May 21, 2025	Non-standard monuments, Monuments, item 5	18
5	May 21, 2025	Removing Monuments, Monuments item 7	18
5	May 21, 2025	Status of Monuments, Monuments, item 12	20
5	May 21, 2025	Examples of Plan Notations, Monuments, Original Monuments, Diagram 1 & 2	21
5	May 21, 2025	Examples of Plan Notations, Monuments, Deteriorated Monuments, Diagram 3	21
5	May 21, 2025	Examples of Plan Notations, Monuments, Lost Monuments, Diagram 2	21
5	May 21, 2025	Curve intersections, Curve Information, item 3 iii e	30

5	May 21, 2025	Legal Subdivision designator, Parcel Designations, item 3	31
5	May 21, 202	T & Y intersections, Street & Intersection Identifiers, item 5	32
5	May 21, 2025	Bank tie from imagery not allowed, Natural Boundaries, item 4	34
5	May 21, 2025	Image of Boundary, Natural Boundaries, item 5	34
5	May 21, 2025	Township Plat information not to be used, Natural Boundaries, item 6 & 7	34 & 35
5	May 21, 2025	Natural Boundary Clarification Table, Natural Boundaries, item 1, 2 & 5 and diagram 5	35 & 37
5	May 21, 2025	Implied Exceptions, Natural Boundaries, Note	37
5	May 21, 2025	Square water, Natural Boundaries, item 8	37
5	May 21, 2025	Defining a bank by centerline or offset, Natural Boundaries, item 10	37
5	May 21, 2025	Feature plans and Natural Boundaries – tie required, Natural Boundaries, item 11	37
5	May 21, 2025	Mouths of Creeks and Rivers, Natural Boundaries, item 15	40
5	May 21, 2025	Consolidations of Quarter Sections, Miscellaneous, item 8	41
5	May 21, 2025	Parcel Class Code Change when bank is out of tolerance, Miscellaneous, item 12	41
5	May 21, 2025	Note: Residual portions of road parcels, Miscellaneous, item 12	41
5	May 21, 2025	Plan of Survey required for Collection Lines, Miscellaneous, item 27	44

5	May 21, 2025	Unnecessary intersection monument to be removed, Miscellaneous, item 36	45
5	May 21, 2025	Primary Re-est width of Road Allowance taken into consideration, Miscellaneous, item 42	48
5	May 21, 2025	Standard Iron Post required at lane corners, Miscellaneous, item 44	48
5	May 21, 2025	Subdivisions in Parks, Miscellaneous, item 46	49
5	May 21, 2025	Correction Lines, Miscellaneous, item 48	49
5	May 21, 2025	5 – sided lines, Additional Diagram, Miscellaneous, item 50	50
5	May 21, 2025	Clarification of 5-sided lines, Miscellaneous, item 51	51

As of May 21<sup>st</sup>, 2025, the above item numbers and page numbers have not been updated with the current manual revision.

6	May 5, 2026	Adjacent Parcel Information and Pending Plans, item 13	14
6	May 5, 2026	Restored vs. Re-established, diagram	23
6	May 5, 2026	Water Body Names, item 1	35
6	May 5, 2026	Imagery with Ground Truthing – Physical Tie Required, item 4	35
6	May 5, 2026	Right of Way Area Breakdown Clarification, diagram	40
6	May 5, 2026	When to define a boundary, item 14	43
6	May 5, 2026	Urban Easement, item 28 & diagram	46
6	May 5, 2026	Rural Easement, item 29 & diagram	47
6	May 5, 2026	Power Box Easement Scenarios, item 30 & diagram	48

## TABLE OF CONTENTS

Overview ..... 13

Plan Format..... 13

General Plan Requirements ..... 18

    Monuments..... 18

    Details ..... 24

    Curve Information..... 25

    Areas ..... 31

    Parcel Designations..... 32

    Natural Boundaries ..... 35

        Natural Boundary Clarification Table..... 36

Miscellaneous ..... 42

## Overview

This document provides additional information and clarification on standards for plan preparation and survey procedure and applies to all plan types approved under [The Land Surveys Act, 2000](#).

## PLAN FORMAT

1. A plan must not exceed 860 mm in width or 3,000 mm in length. *Plan & Digital Size*  
 Please note that Plan Submission Online currently only accepts files no larger than 8mb with the total file size of all files being submitted per request not exceeding 16mb.
2. The GIS area covered by the plan is not to exceed 36 square miles. It is preferable that plans do not exceed one township or range in length.
3. An area of at least 20 mm but not more than 40 mm in width around all edges of a plan is to be kept clear of any information. *Borders*
4. The plan must be oriented with the north arrow pointing up, unless the plan is longer than 914 mm. In this case, the plan is to be oriented lengthwise. This provision does not apply to urban areas. *Orientation*
5. All plan information and the title block should be readable from the bottom right hand corner of the plan to ensure consistency in the placement of the text. This eliminates the need to rotate plan images to read the plan.
6. A title block is required on every graphical plan. *Title Blocks*
  - a) The legal land description of the parcel(s) being subdivided, including the quarter section(s) is required to be stated in the title block.
  - b) The plan type is required to be stated in the title block, and in the case of dual type plans, each individual type is required to be stated. The subdivision of a parcel and the consolidation of the remainder of the parcel to an adjacent parcel would be a Plan of Survey showing Surface Subdivision and a Descriptive Plan – Type II showing Surface Consolidation.
7. Legal Subdivisions in the title block must be shown as being in the Section and not within the Quarter Section. E.g.: LS13, Sec 14, Twp 3, Rge 8, W2Mer.
8. Company logos are acceptable, provided they do not include full or partial addresses, telephone numbers, or any other form of advertising. All slogans, text, images, or material that promotes developments or subdivisions are prohibited. Plans that contain any form of advertising or promotions, including registered trademark/copyright symbols will be required to be removed before the plan can be approved. *Advertising*

9. All plans submitted must be clear in detail, complete as to information, and must scale accurately. The standard plan scale must be 1:10,000, 1:5,000, 1:2,000, 1:1,000, 1:500, 1:200, or 1:100. *Scales*
10. Plans that plot illegibly or appear faint will be returned to address the issue. *Illegible Plans*
11. a) All road allowances on a plan must be shown as solid lines. *Line Types*  
 b) All titled boundaries such as quarter lines, legal subdivisions, parcels, etc. must be shown by solid lines.  
 c) All Feature Plans must be shown as dashed lines. Easement Instruments or registered interests are not to be shown on the new plan unless they are represented by a plan within the Land Surveys Directory.
12. a) The full extent of the source parcel must be shown as solid lines and at a standard scale as specified in item 9 above. If this is not possible, the extent of the source parcel should be shown on a key plan. *Source Parcels & Key Plans*  
 b) Key plans must be drawn to scale. If they are drawn to a standard scale as specified in item 9 above, the scale is to be displayed. If the key plan is drawn at a non-standard scale, the scale must not to be shown. The notation “Not to Scale” must not be shown on the key plan.  
 c) Where the entire quarter section is shown on a plan, all Surface and Feature plans must be shown. As well, all water bodies by implied exception must be shown as per the Natural Boundaries section of this manual.  
 d) If the source parcel is an NTS Map Sheet, the entire Map Sheet must be shown in the Key Plan and the source parcel labeled Map Sheet # \_\_\_\_-Ext. \_\_\_\_.  
 e) Feature plans may be omitted from key plans, except when the Feature plan is the purpose of the plan.
13. At minimum, portions of all parcels (including converted Metes and Bounds plans) immediately adjacent to the source parcel must be shown. If the adjacent parcel is a street, the name of the street is sufficient. The opposite limit of the street is not required. When adjacent parcels are subject to a pending plan, the pending plan information is to be shown. *Adjacent Information*
14. Sufficient information must be shown to give a geographical location to the survey. Excessive reference information outside the source parcel that is not required to provide a geographical location will not be examined for its correctness. *Geographical Location*
15. At minimum, portions of all parcels (including converted Metes and Bounds plans) immediately adjacent to any surveyed lines must be shown. Breaks in the surveyed lines may be used provided it is clear as to the location of the tie line. *Surveyed Lines*

16. In preparing a plan, appropriate abbreviations listed in Appendix 2 of *The Land Surveys Regulations* must be used. If an abbreviation that is not listed is used, then that abbreviation must be shown in the plan legend. The following abbreviations from Appendix 2 and additions are approved for use: *Abbreviations*

<b>Appr</b>	Approach	<b>Mon</b>	Monument
<b>Az</b>	Azimuth	<b>Mr</b>	Marker Post
<b>BC</b>	Beginning of curve	<b>P</b>	Post with Brass Cap
<b>BM</b>	Bench Mark	<b>Past</b>	Pasture
<b>BT</b>	Bearing Tree	<b>PCC</b>	Point of compound curvature
<b>Bdy</b>	Boundary	<b>PI</b>	Point of intersection
<b>Blk</b>	Block	<b>Pits</b>	Four Pits
<b>cs</b>	Countersunk	<b>PI</b>	Planted
<b>CSM</b>	Control Survey Monument	<b>Pr</b>	Principal
<b>Cal</b>	Calculated	<b>Pt</b>	Point
<b>ch</b>	Chord	<b>R</b>	Road Monument
<b>chd</b>	Check measured	<b>R/W</b>	Right-of-way
<b>Conc</b>	Concrete	<b>RM</b>	Reference Monument
<b>Cop</b>	Copied	<b>Rad</b>	Radius
<b>Cor</b>	Corner	<b>Re-est</b>	Re-established
<b>Cult</b>	Cultivation	<b>Res</b>	Restored
<b>Ded</b>	Deduced	<b>Rge</b>	Range
<b>EC</b>	End of curve	<b>Sec</b>	Section
<b>Est</b>	Established	<b>Sm</b>	Small
<b>Evid</b>	Evidence	<b>ST</b>	Subtangent
<b>F</b>	Found	<b>St</b>	Stone
<b>Frac</b>	Fractional	<b>T</b>	Trench
<b>ha</b>	Hectare	<b>TST</b>	Total Subtangent
<b>IP</b>	Iron Post	<b>Twp</b>	Township
<b>IR</b>	Indian reserve	<b>WO</b>	Wooden
<b>LS</b>	Legal Subdivision	<b>WOP</b>	Wooden Post
<b>M</b>	Mound	<b>Wit</b>	Witness
<b>Mer</b>	Meridian		
<b>Mkd</b>	Marked		

17. The minimum lettering size shall be:

Heading	6.0 mm
Legend	2.5 mm
Survey Information	2.0 mm
Section Numbers	6.0 mm
Twp, Rge, Mer	4.0 mm
Areas	4.0 mm
Site Names	6.0 mm
Street Names	2.5 mm
Lot Identifiers	2.5 mm
Block Identifiers	4.0 mm
Parcel Identifiers	4.0 mm
Approved/registered	
Plan Numbers	2.0 mm

*Text  
Sizes*

18. Where there is a change in Township or Range, the Township or Range lines must be clearly labelled on each side of the road allowance.

*Twp &  
Rge*

19. The legal land description (LLD) along with a new extension number for all the remainder portions of the source parcels must be displayed.

*LLDs*

a) The Quarter Sections affected by the new survey must be completely described and shown as follows:

i) At center of section



Section Number: 6.0 mm (minimum)

Location: 4.0 mm (minimum)

ii) ¼ designation : **NE 23-26-12-W 3 Mer – Ext. 1**  
4.0 mm minimum

iii) The quarter section must be labelled on the plan proper.

b) Parcels or lots affected by the new survey must be completely described and shown as follows:

i) Block or Parcels: **A – Ext. 1** 4.0 mm (minimum)

ii) Lots: **1 – Ext. 1** 2.5 mm (minimum)

20. The following apply to Community Names in plan headings:

- a) If the community name appears in the Sask. Municipal Directory System, it must be shown in the plan heading, regardless of whether it is a city, village, or organized hamlet.

<http://www.mds.gov.sk.ca/apps/Pub/MDS/welcome.aspx>

- b) If the community name is for an organized hamlet or smaller, the Rural Municipality name may be included in the heading.

21. a) For northern plans outside urban areas, the LAT and LONG and Map Sheet numbers must be shown in the title block. No reference to “Projected” LLDs is to be shown.

*Northern Plans*

- b) For northern plans within an urban area, the LLD of the plans affected and the urban name must be set out. No reference to LAT and LONG or Map Sheet numbers are to be shown.

22. a) For re-establishment plans in rural areas, the title block is to show Township, Range and Meridian only.

- b) For re-establishment plans within an urban area, the lot, block/parcel, plan number, LLD of the of the quarter section, and the urban name of the area affected must be set out.

23. a) A re-establishment plan titled “Plan of Survey Showing Surface Monuments Established” may be submitted for a pipeline Right of Way that was surveyed, but never constructed. These plans would only be shown on a subsequent plan if the established monuments were used for re-establishment purposes.

*Surface Monuments Established Plans*

- b) For Feature Right of Way and Surface Monuments Established plans, the title block must reference the quarter sections in the portion of the plan that shows the surface monuments established.

24. The Certificate of Surveyor must be signed, sealed, and dated, and must match the title block of the plan. The date and scale are optional to be shown.

*Certificate of Surveyor*

25. The number of the Rural Municipality must be set out with no zeros (e.g. No. 6 instead of No. 006).

*RM Numbers*

26. All items in the Legend that do not apply to the plan must be removed.

*Legend Items*

## GENERAL PLAN REQUIREMENTS

For more information, see the *Saskatchewan CAD File & Geo-referencing Specifications* on the ISC website.

### Monuments

[The Land Surveys Act, 2000](#) – Section 2(t) “monument” means any prescribed device or object used by a surveyor to mark, reference or witness a boundary.

1. As per Appendix 2 and pursuant to section 8, both of [The Land Surveys Regulations](#), the following symbols are approved for use:

*Standard Symbols*

- ◆ - Found or deteriorating monument
- - Established, re-established, or reference monument
- ▲ - Control survey monument or control reference monument
- X - Lost Monument, Established Point or Established Point

2. a) Complete information must be shown as to the type, markings, condition, and position of monuments found. The survey company identification number can be excluded. The markings found on Brass Caps do not need to be shown; however, the year is required if legible.

*Monument Information*

- b) If the markings on a found primary monument are found in error, the surveyor is required to re-mark the found monument correctly or establish a new monument with the correct markings. This new monument information is to be reflected adequately on the plan.

*Markings on Monuments*

- c) If the markings on a found monument are deemed illegible, the surveyor is required to reflect as such on the plan.

- d) All monuments established for new railway and right of way surveys require the monuments to be marked with the letters “RW” or the initial letters composing the name of the company that has the interest in the railway or right of way. Examples of some monument markings are CNR, CP, TCPL, RW, etc.

3. Sufficient information must be shown to clearly define the manner in which a monument has been re-established. In the case where the surveyor is utilizing occupational or field evidence to re-establish a lost primary monument, an evidence sketch outlining what information was utilized needs to be submitted with the surveyor’s report. This sketch will include the date, the land location, and all distances and labels of any items, such as fence lines, fence corner posts, field lines, center lines of roads, or other items identified and assessed during the survey. The monument notation must include the evidence used – see “Examples of Plan Notations”.

*Field Evidence Sketches*

4. A standard iron post must be established at the corners of all parcels, or an acceptable reason for not being able to do so must be provided. This provides clarity for when monuments are found off section or quarter section lines or other surveyed boundaries after the line has been surveyed; i.e. road monuments where tie line was not previously surveyed. A detail, if required, may be shown moving the monument from its original position to the corner of the new parcel. The detail will need to show angular and linear ties from the found monument position, shown as a ghosted diamond, to a new monument position, shown as a solid diamond. If a monument is unable to be planted at a parcel corner, a reference monument marked RM must be placed on one of the new parcel boundaries referencing that corner. This reference monument provision only applies to rural settings.

*Monuments at all Corners*

5. Non-standard monuments (such as bolts, pipes, etc.) will be acceptable if found and shown on a previously approved plan. If these non-standard monuments have not been reflected on a previously approved plan, they must be replaced with a standard iron post.

*Non-standard Monument*

6. Where informal referencing is used, the monument notation on the plan must show the date of reference and date of re-establishment. See “Examples of Plan Notations”.

*Monument Notation*

e.g.  
 FIP – June 1, 1998  
 Destroyed by construction  
 PI IP Mr. – Sept. 1, 1998

7. Where the surveyor has removed a found monument that does not govern, for example a primary monument re-established in error, the monument must be tied in to show its original location.

*Removing Monuments*

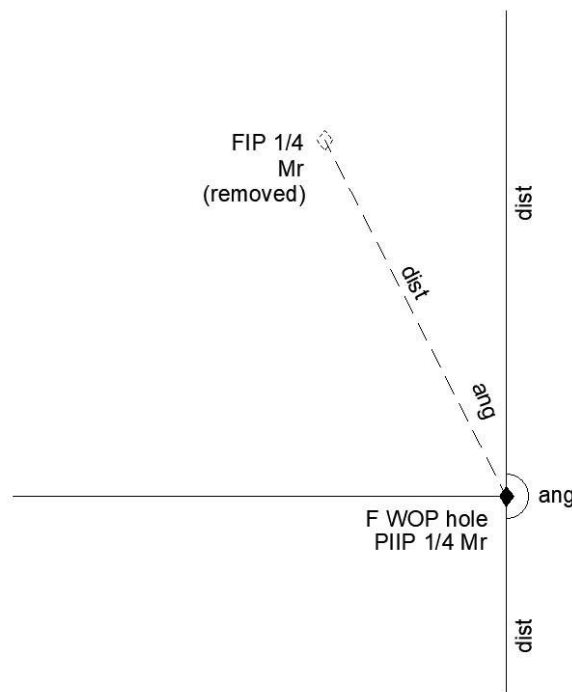

8. Where a surveyor is showing a secondary monument offline, it is to be shown on the production of the boundary that it governs. In the situation where the secondary monument does not define a boundary, a 90° tie is to be used. Angular and linear dimensions can however be used to show the correction in position of re-established primary monuments.

*Offline  
Monuments*

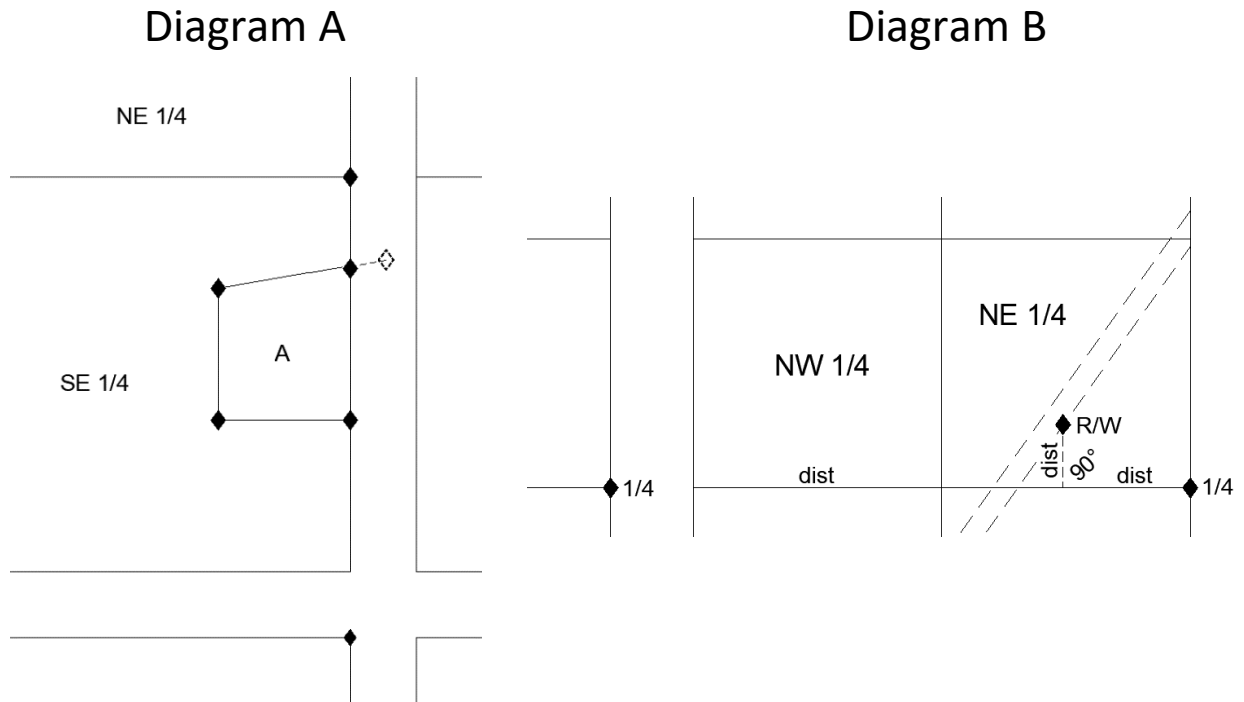

In diagram A, the monument found in the road allowance must be moved onto the section line using the bearing of the found monuments. This bearing governs the north limit of parcel A, but the monument in the road allowance does not govern in place, as it falls within the road allowance.

In diagram B, the secondary right of way monument is found off the quarter line. This monument governs in place and a 90° tie from the quarter line is to be used, as it does not define or govern the quarter line but governs the limit of the right of way.

9. When re-establishing the position or a primary corner from a road monument that was originally established at 90° to the primary corner, the 90° angle shall be taken from the direction of the lower marked road monument. When the lower marked monument is lost, the next higher marked road monument may be used.
10. When common monuments are shown on multiple plans surveyed by the same surveyor during the same time-period, one plan must show the monuments as planted and the remaining plans must show them as found.
11. When it is necessary to re-establish monuments required for the new survey, angular and linear measurements are required from the re-establishment to the new survey.

*Re-est from  
Road  
Monument*

*Common  
Monuments*

*Connections  
To Other  
Surveys*

12. All previously planted standard iron posts coincident with the exterior boundary of a new subdivision must be searched for and their status shown on the plan. This applies to all linear and curvilinear boundaries. In the situation that these monuments are non-governing, they are not required to be searched for and their status shown on the plan. An example of a non-governing monument is a secondary monument not of record. *Status of Monuments*
13. If monuments are found at the corners of a Metes & Bounds parcel, the Metes & Bounds description governs the limits of the parcel and not the monuments. *Metes & Bounds Desc.*
14. A surveyor must provide the status of all survey monuments that would impact their survey on their plan. Monuments cannot be removed from the plan following the discovery of a survey problem. *Showing All Monuments*
15. When locating a monument that is found deeply recessed in the ground (more than 1.2 metres), a new monument can be placed above the existing monument. This new monument must be marked identical to its predecessor and noted on the plan. *Recessed Monuments*
16. Specific to the establishment of a new witness monument, it is required to be marked in metres and shown to the nearest full multiple of 0.1 metres and in Arabic and not in Roman Numerals. When dealing with an existing witness monument position or re-establishing an existing witness monument position, the distance on the plan is required to be shown in metres with the monument notation in chains. The witness monument notation on the plan is to match the markings on the monument. *Witness Monuments*
17. Monuments must be drawn at a suitable size so as not to be obscured by plan lines, road lines, or the line of approval. *Monument Size*

### Examples of Plan Notations

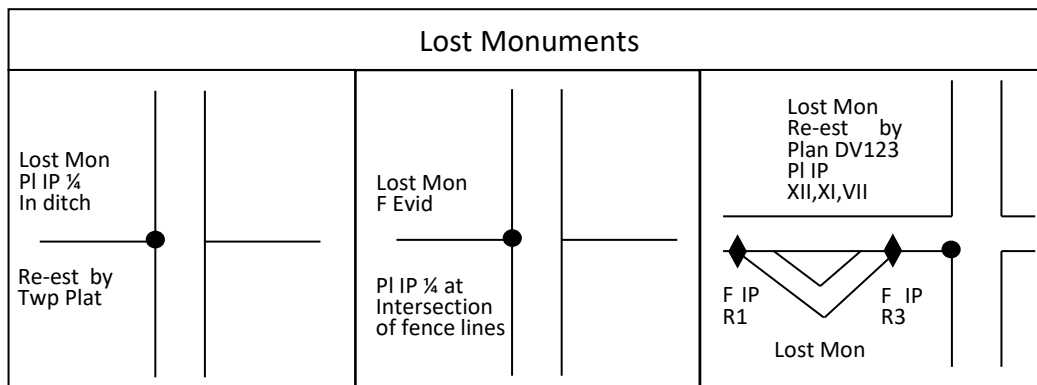
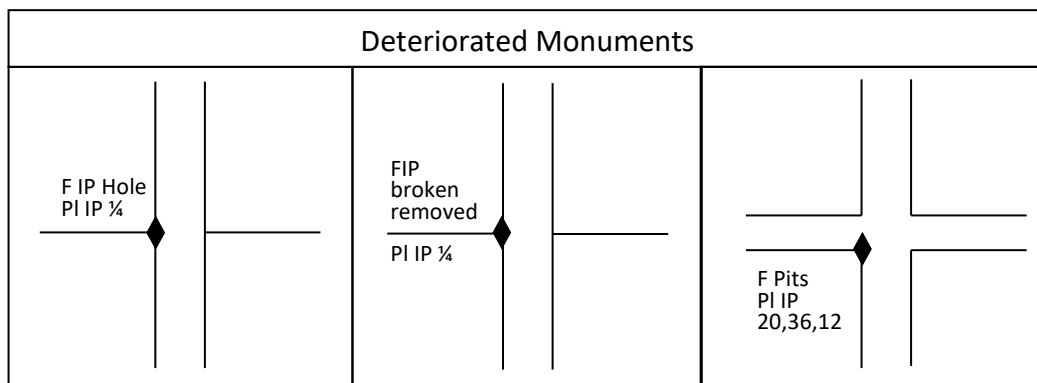
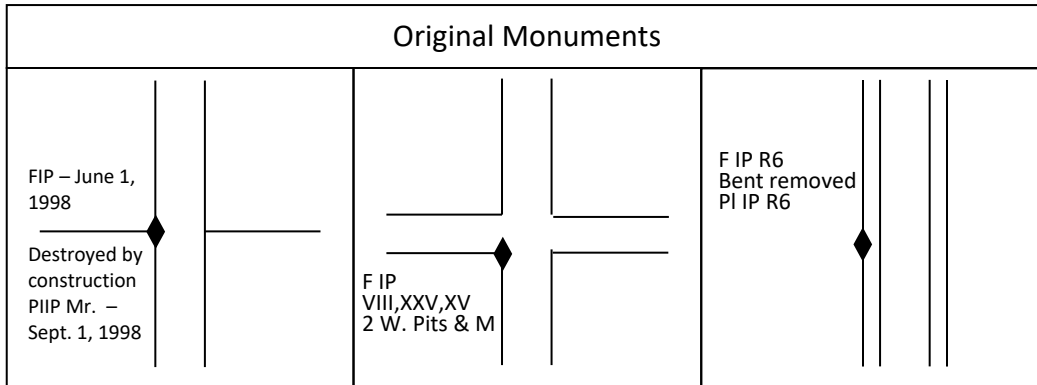

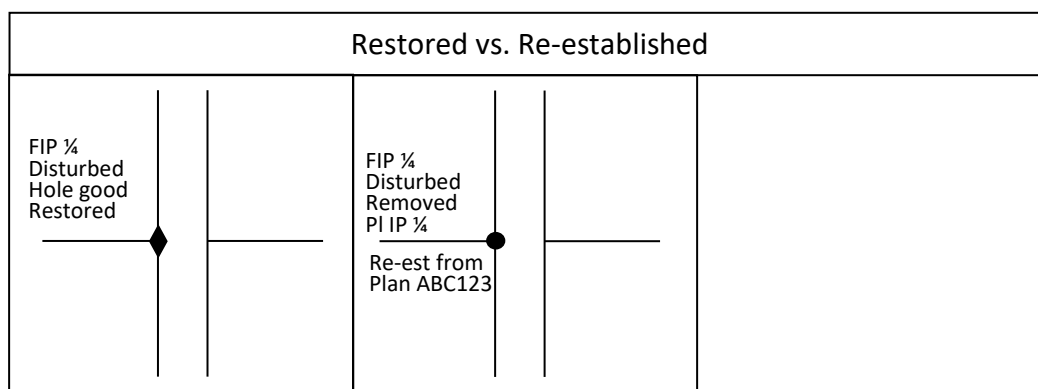
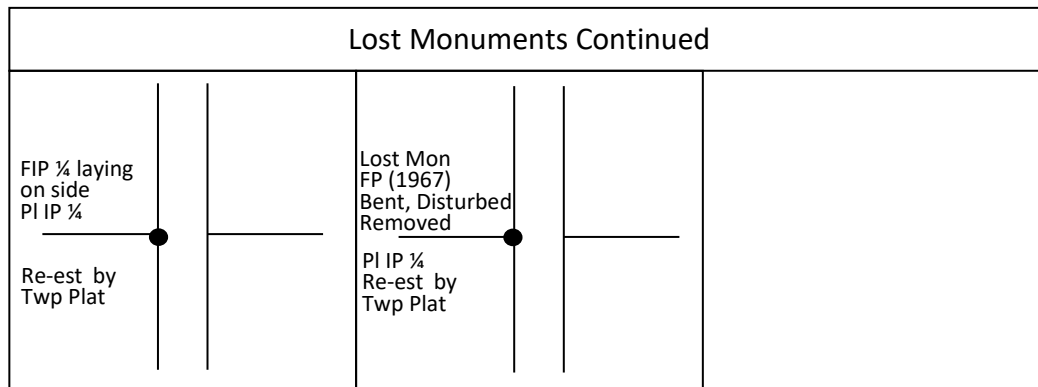

**NOTE** All monuments shown on the plan must be labeled as to the type of monuments found (or planted) along with their markings.

- 18. A solid diamond symbol is to be used to indicate when the monument or trace of the monument has been located to define the monument’s position. A solid circle symbol is to be used when a monument has been determined to be lost or disturbed and the position of the monument cannot be defined. To clarify, when evidence such as fence lines or field lines are accepted, a solid circle is to be used.

*FIP vs.  
F. Evid*
- 19. If a cut cross is established, it is considered a monument and must be shown on the plan as a solid circle with the label “Cut Cross”. A found cut cross must be shown on the plan as a solid diamond.

*Cut Cross*
- 20. When a monument is lost and its position is being re-established, notation on the plan is required to be shown as to what has occurred (e.g. “Lost Mon. Re-est Pt by Plan...” or “Lost Mon. PI IP by Plan...”).

*Lost  
Monuments*
- 21. When a monument is inaccessible and the surveyor cannot deem the monument as lost, the plan should show “Est. Pt.” and not “Lost Mon”.

*Inaccessible  
Monuments*

22. In situations where there is a buried utility, concrete, or concrete curbs present, etc., it is acceptable to show on the plan proper an established point along with a reason for not planting a monument (e.g. Est. Pt. ground disturbance policy) as opposed to placing a standard iron post. In the situation where it is not a permanent feature, such as construction, vehicle, rock pile, etc., a standard iron post is to be established.
23. When conducting a survey and the top of a standard iron post is broken off, or the monument is deteriorated, the surveyor is required to replace with a new standard iron post. In the case of a found post where the cap is broken off, this monument would not be required to be replaced. If a found post or standard iron post is bent, it must be straightened or replaced. This applies to all monuments: standard iron post, iron posts, and 5 foot township monuments.
24. All found monuments are required to be confirmed that they are in their original undisturbed position prior to carrying out any new surveys. Where the confirmation requires measurements that are beyond the extent of the survey, these measurements are required to be shown on the plan. Where measurements to monuments cannot be obtained for confirmation, a complete report outlining the methods used to confirm the position of these monuments must accompany the plan of survey.

*Deteriorated  
Monuments*

*Confirmation  
of  
Monuments*

## Details

1. Where sufficient space does not exist on the plan proper, the information may be shown on a detail, drawn to a size that is sufficient to clearly show the information. The detail does not have to be drawn to scale. However, it should be drawn proportionately, so it is clear as to its survey content.
2. In situations where it is unclear how a monument or corner has been established, whether it be on the plan proper or in a detail, a detail or an inset in relation to a detail will be required.
3. Wherever possible, all details must be drawn outside the source parcel.
4. Wherever possible, details must be numbered or lettered in a consecutive manner and shown adjacent to the affected parcel.
5. Where sufficient space exists to link plan proper and detail together, at minimum, monuments with notations must be shown on the plan proper, and a notation indicating “See Detail \_\_\_\_” to coincide with the letter or number assigned to the detail.
6. All details associated with plan proper must utilize a standard scale, as outlined in the Plan Format section. If the detail is not a standard scale, “Not to Scale” is to be noted adjacent to the detail.

*Details*

## Curve Information

### Curves (minimum requirements)

1. Subdivision curves must show separate arc information for each lot, parcel, etc. The total Delta, total Subtangent and radius of the total curve are required to be shown.

Curves

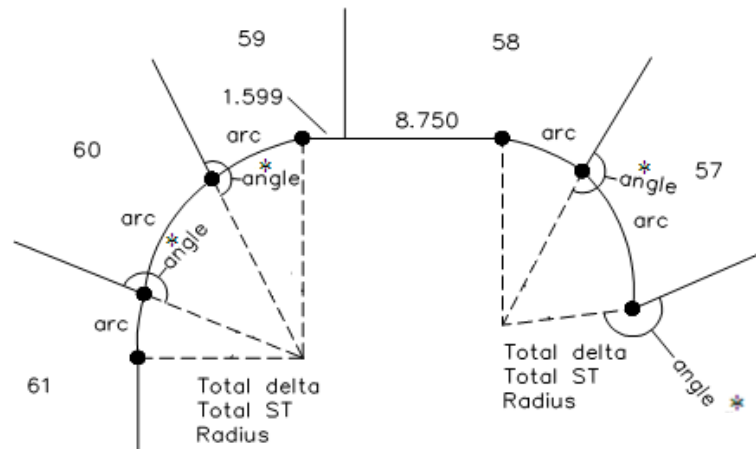

\* When the angle from lot line to radius is not  $180^\circ$  or when the angle from the subtangent to the radius is not  $90^\circ$ , the angles are to be shown.

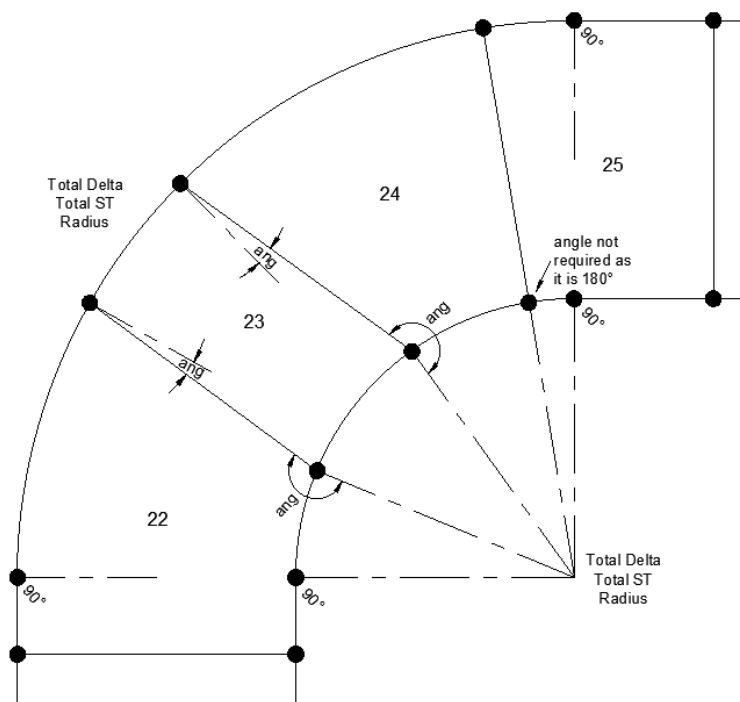

\*Please note that front and back curves are similar curves.

2. Curve information is to be shown as follows: (note the arc must be shown adjacent to the curve in all cases)

i. Simple curves

$\Delta$  . . . . Deflection angle between Subtangents (Delta)

ST . . . . Subtangent

R . . . . Radius

 **NOTE**

*A simple curve consists of 4 monuments: 2 tangent monuments, a Beginning of Curve Monument (BC), and an End of Curve Monument (EC). When it is necessary to define an existing curve, a minimum of three monuments must be found, restored and / or re-established to verify the existing curve information.*

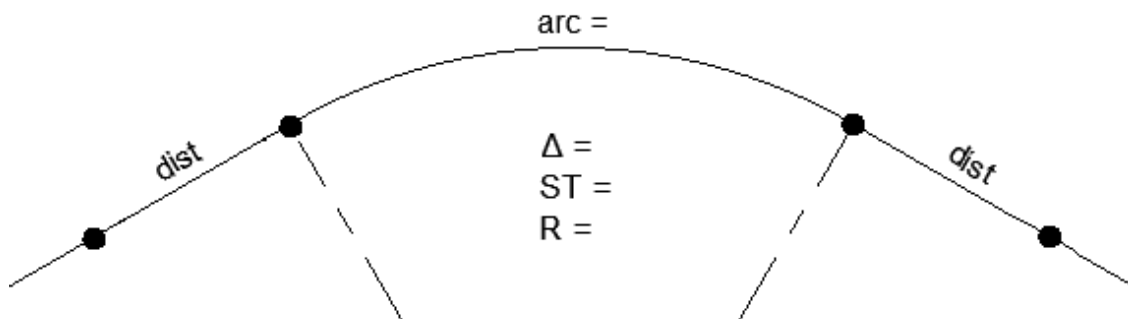

- ii. Replacement of planned or constructed spiral curves must show three simple curves and include the total Deflection Angle ( $T\Delta$ ) and total subtangent (TST).

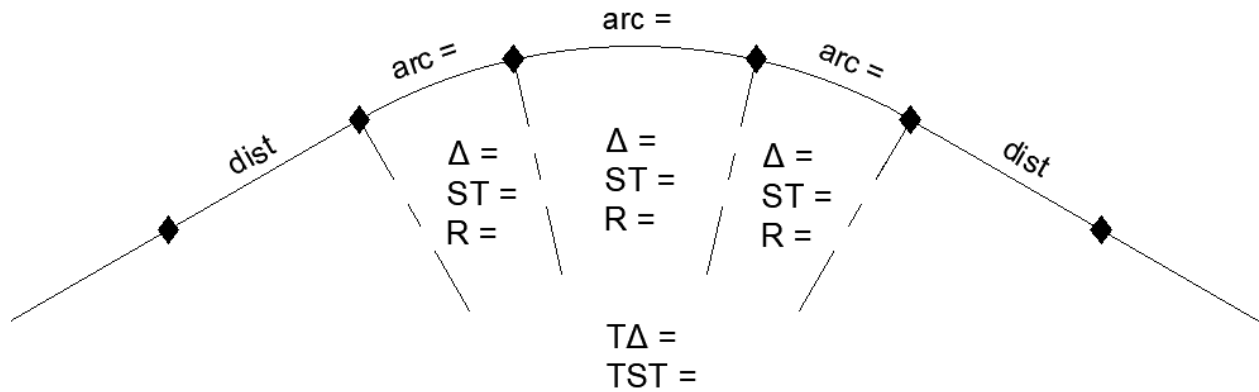

- iii. Retracement of existing replacement curves based on formerly prescribed tables (Arc definition for roads and Chord definition for railways) must show three simple curves and include the Total Subtangent (TST) and Total Delta ( $T\Delta$ ).

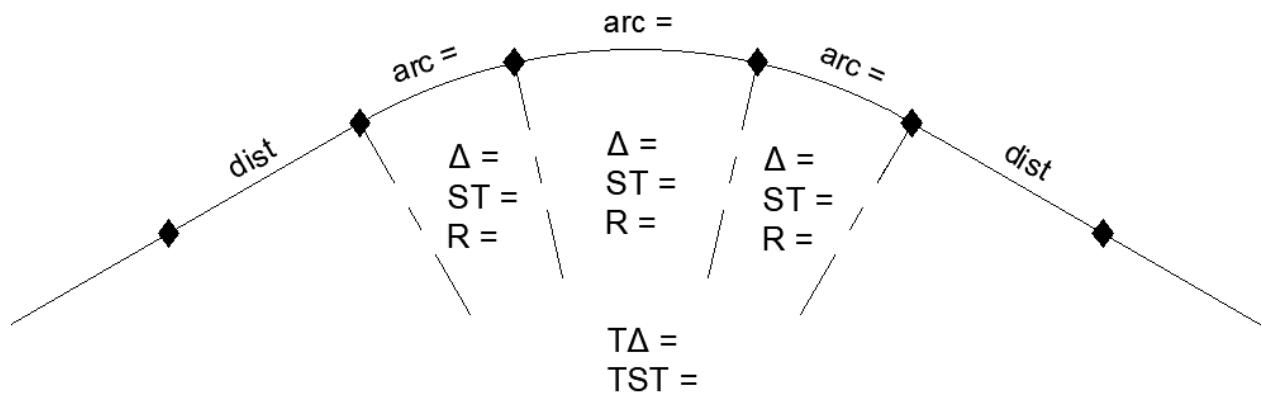

3. When referencing curve information including intersections, the following methods can be employed.
  - i. Distance from BC and/or EC to intersection on subtangent or chord.

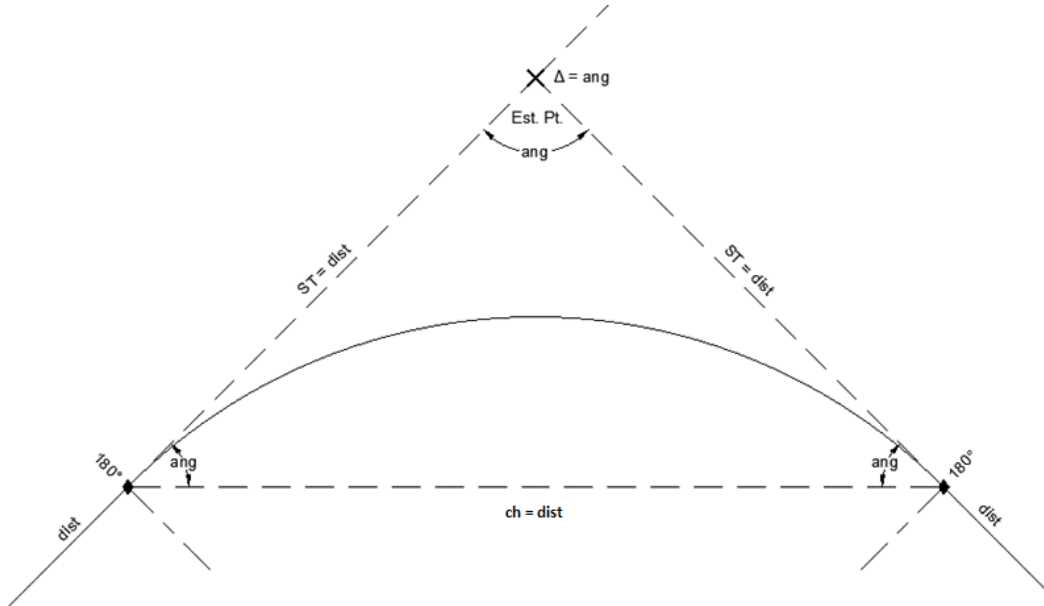

- ii. Angle with subtangent or chord at intersection.

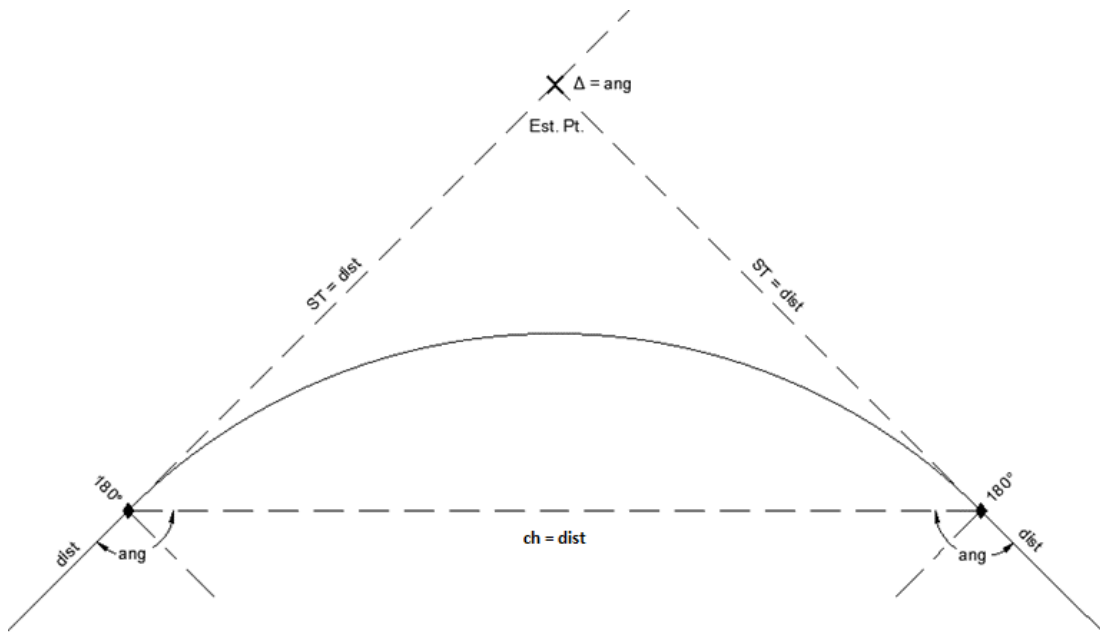

iii. The following five diagrams are acceptable options for intersecting a surveyed lined with a curve.

a.

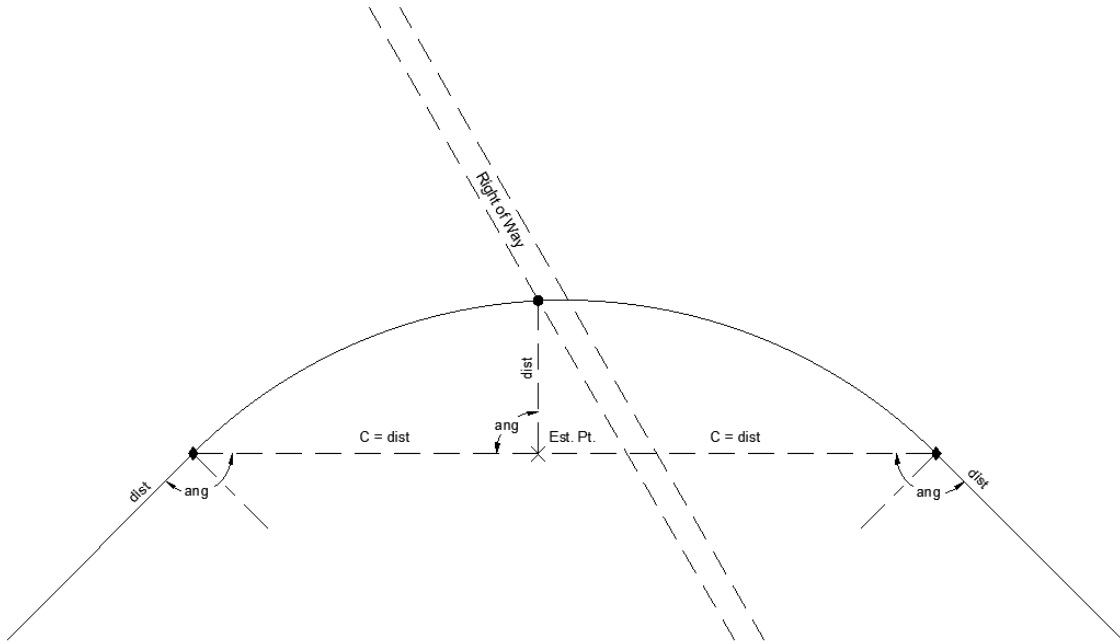

b.

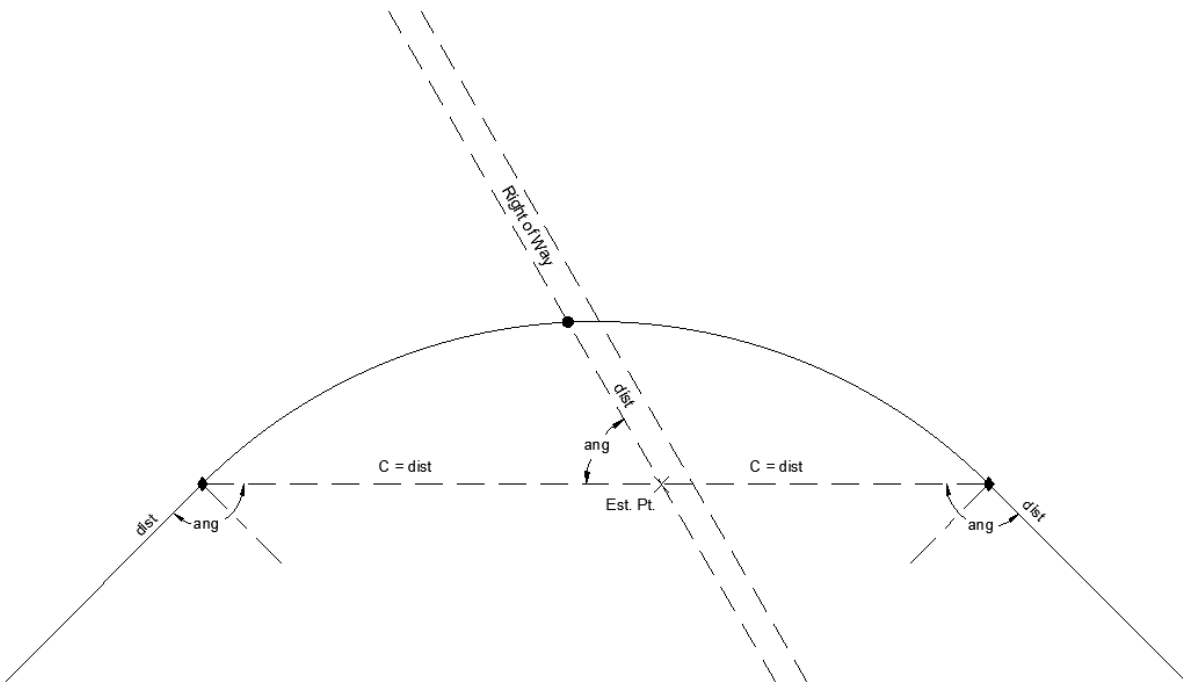



e.

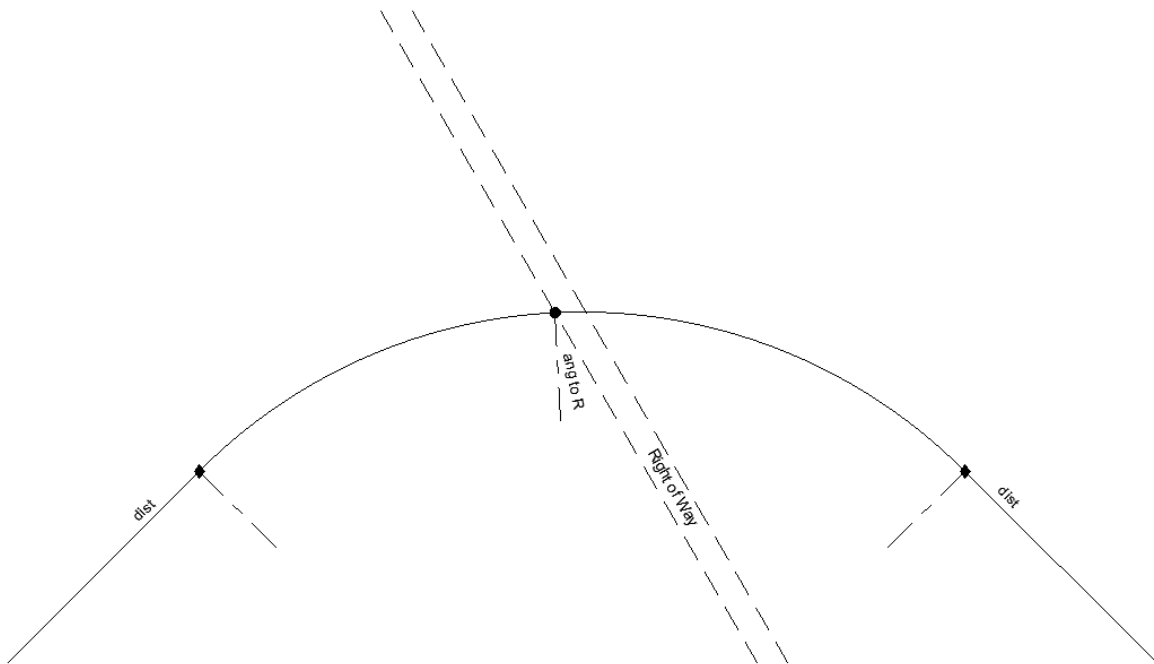

## Areas

1. Areas on Right of Ways (Feature plans) must be shown to the second decimal point in hectares within the source parcel. In situations where the area is less than 0.01ha, the area can be shown up to the fourth decimal.
2. Areas for canals and railway plans (both Feature and Surface) must be shown to the second decimal point in hectares within the source parcel. In situations where the area is less than 0.01ha, the area can be shown up to the fourth decimal.
3. Areas must not be shown on DP1 and DP2 Easements.
4. For areas for road plans, see the Road Survey Guide.
5. Supplemental Township Plat Areas are to be shown to one decimal place.

*Areas*

## Parcel Designations

1. All new parcels must have a parcel or lot/block identifier, usually shown as letter(s) or number(s); however, some identifiers require a combination of both. These include the following:

*Parcel  
Designations*

Streets - S#.

Street Intersections – SX#

Lanes – L#

Public Reserves – PR#

Municipal Reserves – MR#

Walkways – W#

Environmental Reserves – ER# (a note shall be shown on the plan stating where Title to ER will be issued to)

Municipal Environmental Reserves – ER# (a note shall be shown on the plan stating where Title to ER will be issued to)

Buffer Strips – PB#

Municipal Buffer Strips – MB#

Municipal Utility – MU#

2. When a quarter section is reset by a consolidation, the quarter is required to maintain the quarter LLD and not have a parcel designator.
3. The legal subdivision designator (LS) cannot be used for a new surface or mineral parcel. The parcel designator for a new LS can be either a letter or a number.
4. When dedicated lands, such as MR, ER, & MB, are created in the name of a municipality (urban or rural), the municipality name must be displayed on the plan as stated in [The Dedicated Lands Regulations](#). In most cases the municipality's name would be displayed in the title block.

- When streets, street intersections and lanes are created, the resulting parcels must be assigned unique identifiers as mentioned above. The street intersections must be shown as fine dashed lines and the ends of lanes must be closed off with solid lines. If a street is continuous but the street name changes at a designated dividing line, indicate this dividing line on the plan with a fine dashed line and assign unique street identifiers to the parcels on both sides of the dividing line. If one continuous street with the same street name is creating a “T” or “Y” intersection, the street is required to be shown with different S# designators. Alternatively, the street can be broken up with an intersection SX# designation.

*Street & Intersection Identifiers*

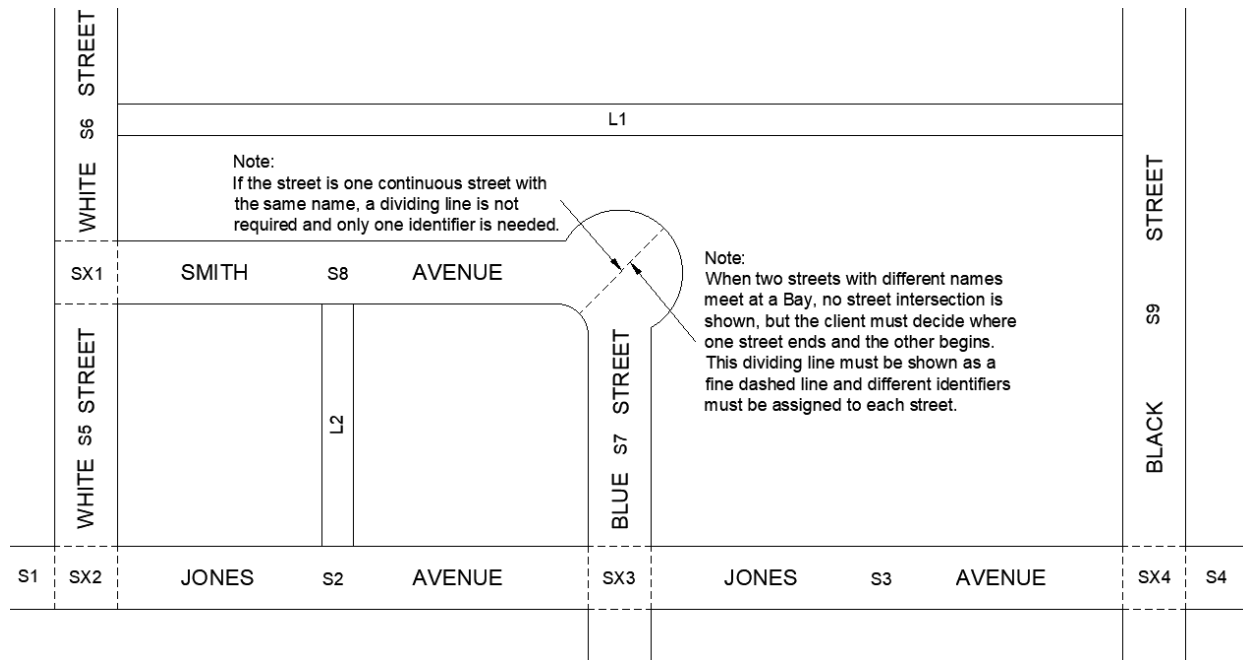

- The duplication of parcel identifiers within the quarter section or block is not encouraged.
- Within the line of approval, the lanes must be closed, but street intersections must be dashed. Outside the line of approval, the lanes and streets should be open.
- In situations where a street corner is cut-off on the exterior of a subdivision, the parcel identifier for the parcel may be shown as street intersection (SX#) or street name (S#).

*Parcel Designators as Reference Information*



- Road widenings on subdivision plans must be given a parcel identifier. If the new road widening is adjacent to a street, it is considered an extension of that street, so it should be given an identifier of S#. The road widening must also be labeled with the street name. If the new road widening is adjacent to a road allowance or road plan, it is considered an extension of the road, and therefore should be given a parcel designator of A, B, C, etc. or G, as shown below. Road widenings on any plan other than a road plan must be labeled “Road Widening”.

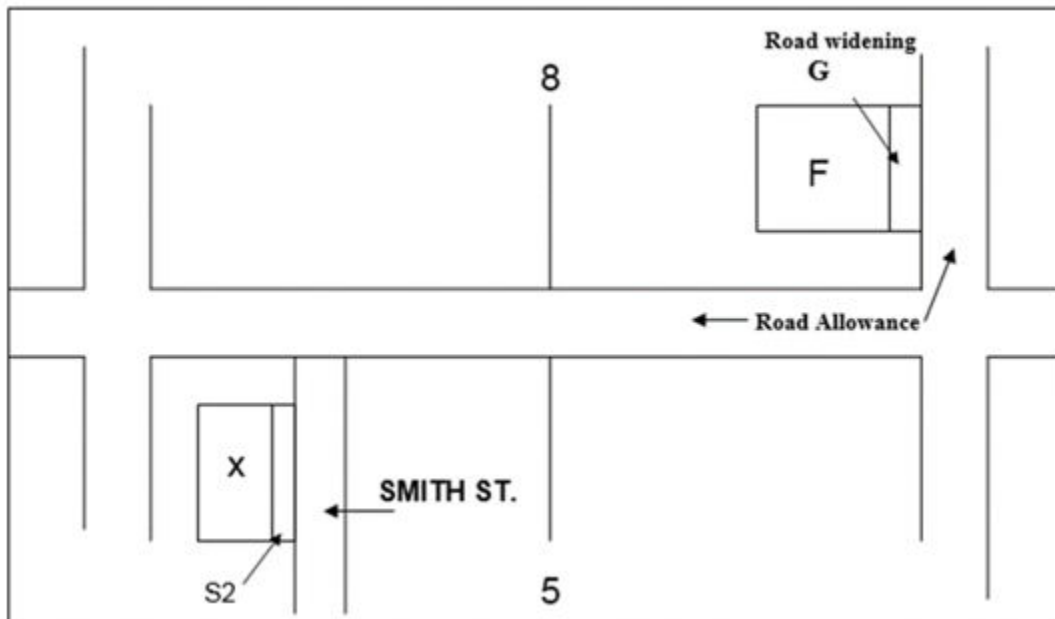

- Street/Road Widenings shown as reference information on plans must be shown as follows:

If the widening has a parcel identifier of street (S1, S2, etc.) in GIS, the interior line between the widening and the street must be shown as a dashed line. If the widening has a parcel identifier of road widening (A, B, etc.) in GIS, the interior line between the widening and the road is to be shown as a solid line.

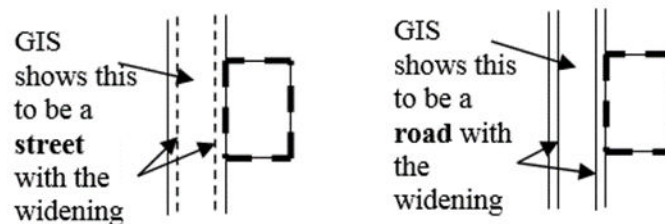

- Streets shown as reference information and having different names or different plan numbers do not require a solid line be shown between the two streets.
- All lot, block, and parcel designators must be in capital letters.

13. On Feature plans, a unique parcel designator in the form of a letter may be assigned to the new right of way within each source parcel. The lettering must be consecutive and unique throughout the plan.

## Natural Boundaries

1. Natural boundaries must be designated clearly on the plan. Where the bank is taken as the boundary, the bank is to be determined as defined in Section 32 of [The Land Surveys Regulations](#), subject to other applicable legislation, judicial decisions or existing rights. The water body name, and when applicable, the bank(s) and direction of flow must be shown.

*Natural  
Boundaries*

The water body name is to be obtained from the latest Township Plat Edition and the NTS Map Sheet Series for unsubdivided lands, and from MapSearch when the water body has been renamed.

2. A note is to be shown on the plan stating “The bank is taken as the boundary. For the definition of bank, see Section 32 of [The Land Surveys Regulations](#)”.
3. When showing reference to a bank, a note must be added to the plan to clearly indicate how the bank was plotted. e.g.:

- “Bank plotted from Township Plat dated \_\_\_\_\_”
- “Bank plotted from 1:60,000 Aerial Photography (Photo \_\_\_\_\_ )”
- “Bank plotted from Air Photo dated \_\_\_\_\_”
- “Bank plotted from Plan \_\_\_\_\_”
- “Bank plotted from GNSS survey dated \_\_\_\_\_”
- “Bank plotted from NTS Map Sheet Series \_\_\_\_\_”

4. Where it is necessary to define or reference the bank at the time of the survey, positions must be shown at each general change in direction. The bank can be defined by field traverse or offsets, Global Navigational Satellite System (GNSS) or imagery (e.g. satellite imagery, LIDAR, Infra-red, and orthomosaic imagery collected via drones) with ground truthing.

When the surveyor utilizes imagery with ground truthing to define the bank(s), the surveyor is required to provide a physical tie between a monument on the new boundary/boundaries and the newly defined bank(s). In the case of easements, please refer to Policy GO-04/008.

5. When the bank is taken as the boundary, an image of the boundary is to be provided and the location of the bank noted on the image. The image may show the bank marked on the ground in several locations, or the image can be marked at a couple points with the bank location. This image is required to be included in the plan submission as a support document or can be housed in the surveyor’s report.

*Field Notes  
& Images*

6. If the bank is taken as the boundary within a quarter section or parcel, and the current title or abstract is not based on the bank, it is not required to define the remaining portion of the water body. In this case, the water body will be handled as an implied exception for the bed of the water body. The remaining portion of the water body may be shown on the plan as a dashed line for reference only. This cannot be plotted from a township plat edition that defined the water body. When it is applicable to do so, the name, both banks and the direction of flow must be shown. The name requirement applies when the water body is shown on any Township Plat Edition, named in MapSearch or is named on any NTS Map Sheet Series.
  
7. If the bank is not taken as the boundary within a quarter section or parcel, and the current title or abstract is not based on the bank, it is not required to define the water body. In this case, the water body will be handled as an implied exception for the bed of the water body. The water body must be shown on the plan in the target parcel as a dashed line for reference only. This cannot be plotted from a township plat edition that defined the water body. When it is applicable to do so, the name, both banks and the direction of flow must be shown. This requirement applies when the water body is shown on any Township Plat Edition, named in MapSearch or is named on any NTS Map Sheet Series.

*Water  
as  
Implied  
Exception*

### Natural Boundary Clarification Table

#	Scenarios	Legal Plan Requirements
1	An implied exception exists in the source parcel.	If the implied exception falls within the target parcel, the surveyor is required to show the actual bank as reference information through the entire target parcel. The surveyor is also required to show a portion of the actual bank through the source parcel when it is immediately adjacent to the target parcel for plan clarity and has the option of showing the implied exception through the entire source parcel as reference information as well.
2	An implied exception exists in the source parcel.	If the implied exception falls outside the target parcel, the surveyor has the option to show the actual bank as reference information in the source parcel. If the bank is within tolerance of the target parcel as stated in the Water Boundaries Policy GO-12/001 (80m primary), the current bank is to be plotted as a dashed line for the portion of the current bank that is adjacent to target parcel. See diagram 5 below that reflects this requirement.
3	An existing titled bank exists in the source parcel.	If the bank falls within the target parcel, the surveyor is required to redefine the bank as a boundary. The remainder of the bank in the source parcel must be plotted on the plan, as per the plan that title is based on.

4	An existing titled bank exists in the source parcel.	If the bank falls outside the target parcel, but forms part of the source parcel, it must be plotted on the plan as per the plan that title is based on.
5	An existing titled bank exists in the source parcel.	In addition to above #4. If the current bank is within tolerance of the target parcel as stated in the Water Boundaries Policy GO-12/001 (80m primary or 5m secondary), the current bank is to be plotted as a dashed line for the portion of the current bank that is adjacent to target parcel. The surveyor has the option of showing the current bank through the remainder of the source parcel as reference information as well.
6	An implied exception exists in the source parcel and the new parcel is to abut the implied exception.	If the implied exception is intended to be used as a boundary for the target parcel, the bank of the implied exception must be surveyed and the adjacent bank from the surveyed bank is to be shown as reference information. The surveyor has the option of showing the implied exception through the remainder of the source parcel as reference information as well.

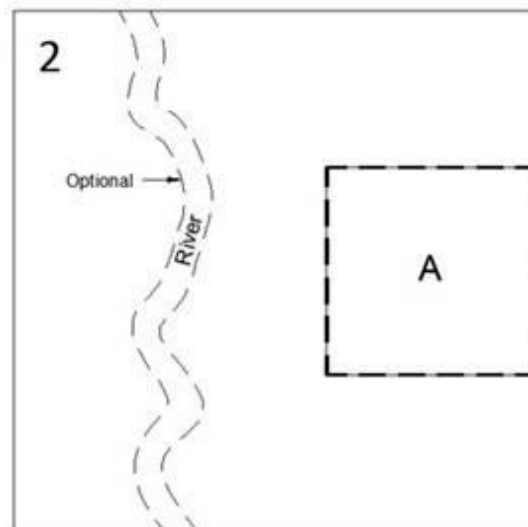
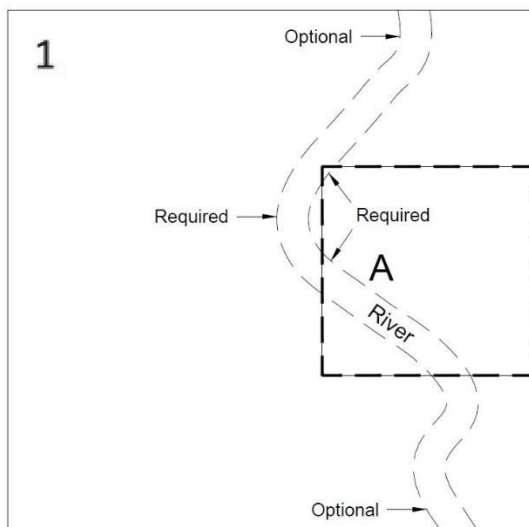

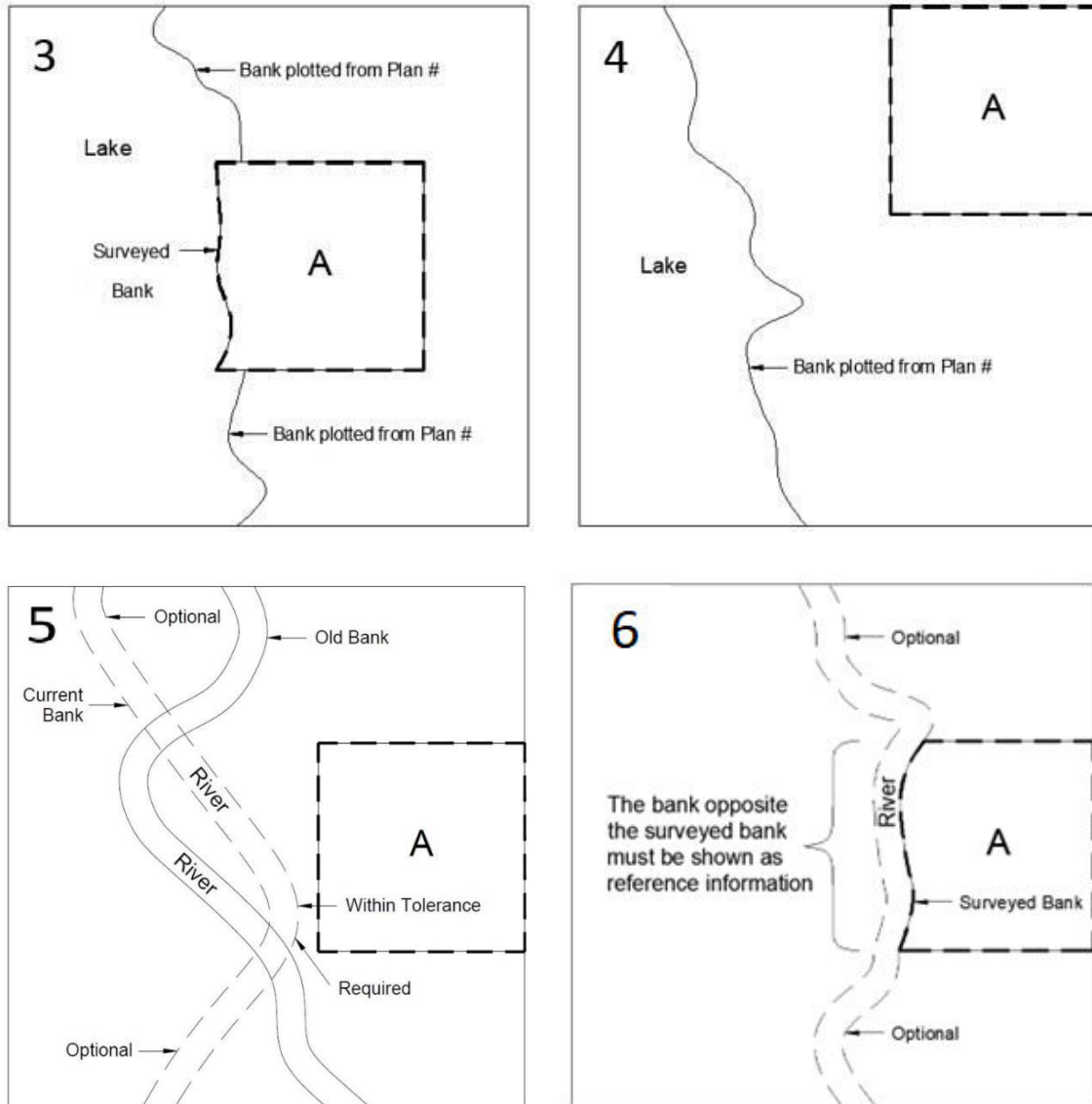

**NOTE** *Implied exceptions are to be shown on all new plans whether the plan is a surface or feature plan.*

**NOTE** *In the situation of an implied exception is within a consolidation, the implied exception is required to be shown on a graphical plan submission.*

8. If a plan is submitted that surveys the limits of a square water parcel, it will be returned. The boundaries of square water are to be handled as a natural boundary under the water policy – Water Boundaries on New Plans – GO-12/001 and not as a rectangular boundary.

*Square Water*

9. In the case where a creek, river, or stream has been channeled due to man-made improvements, the channel must be labelled with the parent name of the creek, river, or stream.

10. Defining a boundary by the centerline or by an offset of a creek, river or stream is not acceptable. The bank is required to be defined unless defined by the above other means has been previously accepted on a plan or a metes bounds description. This does not apply if the bank is found to be not within tolerance, then the bank is required to be defined.
  
11. Where a Right of Way or Easement Plan crosses the bank based on title, the titled bank is to be shown as a dashed line within the feature and the actual bank is to be defined and shown as a solid line within the feature. A small portion of the actual bank must be shown as a dashed line on both sides of the feature and is optional to be shown through the full source.

*Feature  
Plans and  
Natural  
Boundaries*

The feature is required to show a tie from the actual bank to an existing or an established monument on the feature. For Easements, please refer to Policy GO-04/008.

Where the feature crosses the titled bank and not the actual bank, ties from the feature to the actual bank are required. In both situations, a monument must be placed or tied to existing monumentation on the feature limit referencing the actual bank. This does not apply to Descriptive Plans.

Also, where the feature plan does not cross the titled bank and terminates on or crosses the actual bank, the actual bank is to be defined and shown as a solid line. A small portion of the actual bank must be shown as a dashed line on both sides of the feature and is optional to be shown through the full source.

Where the water body has receded and no longer affects the Right of Way, a portion of the actual bank needs to be shown for reference. An area is not to be taken through the titled bank nor reflected in the title block of the plan.

In the last of the diagrams below, A1, A2, and A3 indicate the area breakdowns to be shown.

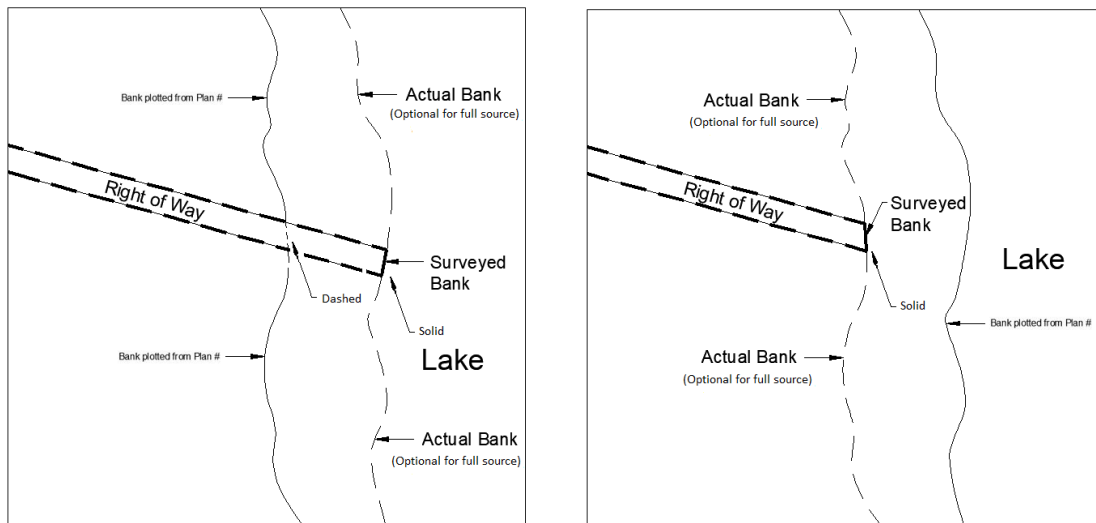

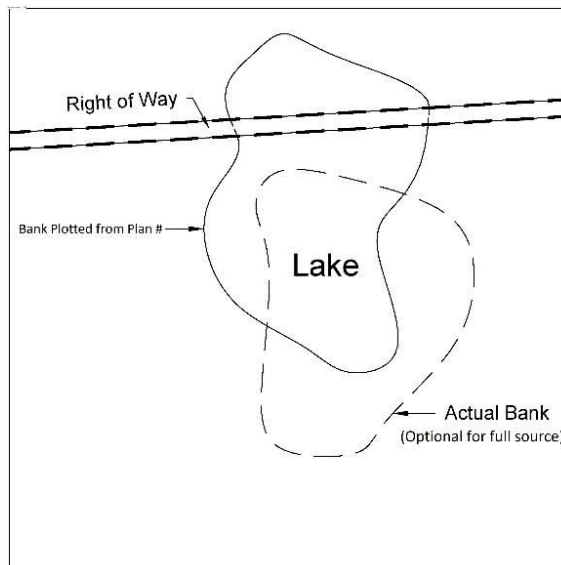
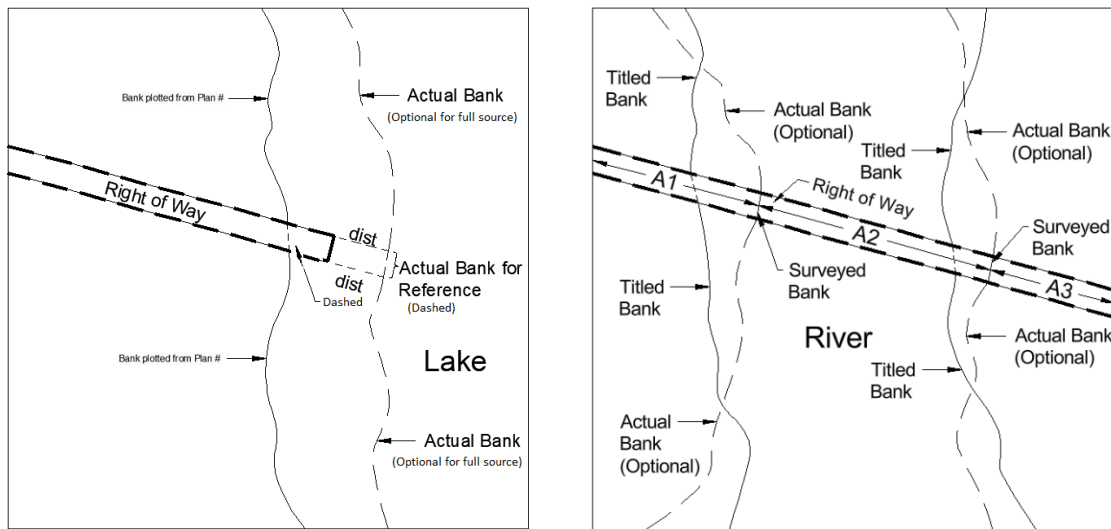

12. Where a Surface Lease (feature) Plan crosses a bank based on title, the titled bank is to be shown as a dashed line within the feature, and the actual bank is to be defined and shown as a solid line. A small portion of the actual bank must be shown as a dashed line on both sides of the feature and is optional to be shown through the full source.

*Surface  
Leases  
and Water*

A monument must be placed on the feature limit referencing the actual bank.

Also, where the feature plan does not cross the titled bank and terminates at the actual bank, the actual bank is to be defined and shown as a solid line. A small portion of the actual bank must be shown as a dashed line on both sides of the feature and is optional to be shown through the full source.

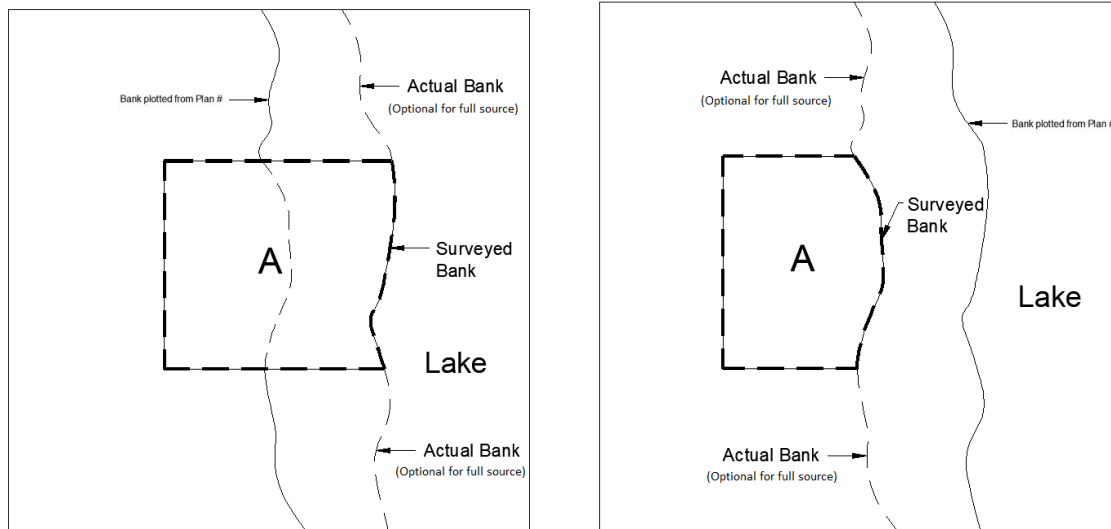

13. If a Right of Way is going through abstracted land and there is no bank shown, then the Right of Way can end on the bank defined on the ground by means under above item 4 on page 25.
14. When a bank cannot be defined due to man-made features or additions such as rip-rap, retaining walls, or fill have altered the existing bank, the previously defined bank as per a secondary plan or township plat is to be used.
15. When the mouth of a creek or river connects with another body of water, the two must be continuous and open. In other words, there should be no bank obstructing the mouth of the creek or river, so it must be represented as a single parcel.

## Miscellaneous

1. Street names must be displayed where portions of urban areas are shown. *Street Names*
2. Condominium plans, shown for reference information, must be labeled "Condominium Plan\_\_" with the underlying subdivision plan number shown in brackets. *Condos*  
 e.g.: Condominium Plan 99RA05654  
 (Plan 96R68343)
3. Centerlines on railway plans are not required; however, centerlines may be shown as a faint dashed line. This is critical when showing the source parcel but is not critical when showing surrounding information. *Railways*
4. The perpendicular width of new Right of Way (Feature) plans must be shown clearly. The perpendicular width of other roads, streets, lanes, and Right of Ways in the vicinity must also be shown. *Widths*

5. Rural and urban municipal admin boundaries related to natural boundaries may be labeled but are not to be shown on plans when they do not coincide with an existing boundary.
6. Consolidation of a titled parcel to an abstract parcel is not allowed. This does not apply when related to a natural boundary under the water policy GO-12/001.
7. In the case of a consolidation from abstract to abstract within a Northern Map Sheet, the Map Sheet Identifier will need to be changed to a parcel identifier with reference to the old Map Sheet number shown in brackets underneath.

*Consolidations*

e.g.: A Ext. 0  
(Map Sheet 76-M/10)

8. Quarter LLDs are to be maintained at all times. As reference, consolidating two adjacent quarter sections with quarter LLDs together, is not allowed. Additionally, this is not allowed by way of a Descriptive Plan Type 2 (DP2) textual plan, DP2 graphical plan, or Plan of Survey showing Surface Subdivision of two quarters to create a single parcel. This also applies to river lots.
9. Consolidation of legal subdivisions within a quarter section is allowed. Consolidation of legal subdivisions outside or beyond the quarter section is not allowed.
10. The full extent of road allowances are not to be consolidated but rather parcel tied.
11. A subdivision of a portion of a road allowance, or subdivision and consolidation of a portion of a road allowance can occur, assuming a remainder quarter LLD and/or a remainder road allowance will exist.
12. When surveying a new parcel in conjunction with a consolidation or a parcel class code change to an adjacent parcel, the plan cannot proceed as a combination plan if the parcel being consolidated to or the parcel class code change includes a natural boundary which is found to be out of tolerance.

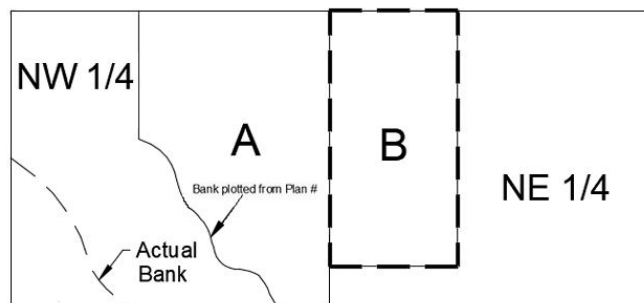

In the example above, Parcel B is a newly surveyed parcel, which was surveyed to be a new addition to existing Parcel A. As per item 12 above, Parcel A and B cannot be consolidated by way of a combination plan (Surface Subdivision and Consolidation), as the bank defined for the southwest limit of Parcel A is out of tolerance. In this situation, a parcel tie could be used to tie Parcels A and B together. For clarity, the retaking of an existing parcel, with an out of tolerance bank, by way of a combination plan, is not allowed.

Note: The consolidation of a residual portion of a road parcel with a parcel with a natural boundary that is found to be not within tolerance, is allowed.

13. If during the course of a survey, which includes combination plans, a monument is used that is the subject of an inspection plan, or has been flagged as a survey problem, it must be resolved. *Inspection Plans & Survey Problems*
  
14. Where a proposed subdivision, right of way, or an easement boundary is within 2.0 metres of secondary fabric, or 10.0 metres of primary fabric, of an existing parcel boundary, quarter section line, or other surveyed boundary, and the impact on that boundary has not been confirmed by monumentation, the surveyor must confirm the boundary by monumentation. *When to define boundary*
  
15. The change in direction and / or width of a Right of Way must be posted on the posted limit. Where a change in perpendicular width occurs on the unmonumented limit, at the same point as the change in direction, the unmonumented side of the Right of Way, does not require to be posted or tied into the posted limit. *Right of Ways*

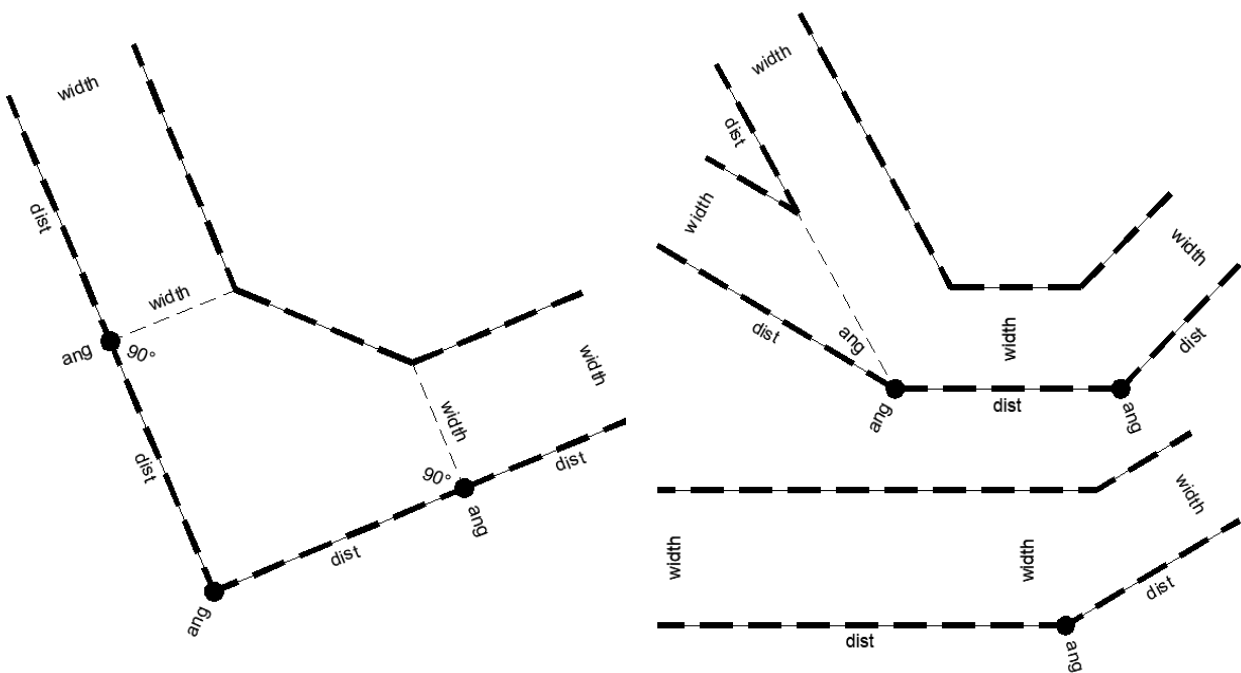

16. For a right of way on unsurveyed provincial lands, the maximum distance between monuments must not exceed 1,000 metres.

17. The surveyed line may be shown as a centerline offset within the Right of Way. In this situation, the surveyed line must be shown as a dashed line or if shown as a solid line, separate area designations must be shown on either side of the surveyed line. If the surveyed line is taken as the centerline of the right of way:
  - a) All survey information/measurements must be related to the surveyed line.
  - b) All angles are assumed to be at 90° (for area calculation only) from the surveyed line unless otherwise shown.
  - c) Any change in direction, width, or position of the centerline, of the Right of Way, must be posted.
  - d) Any change in width which creates a non-parallel width relative to the posted centerline limit must be posted on the unposted limit (bump out situations on transmission line Right of Ways). When all limits are made parallel to the posted limit, no additional posting is required.

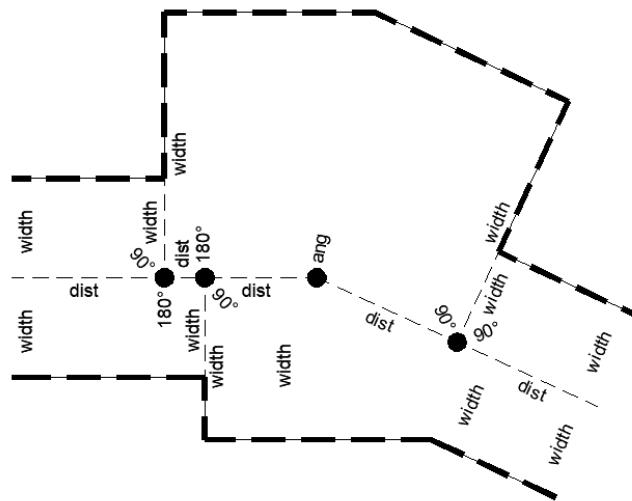

18. When a Right of Way is using found primary monuments or secondary monuments along a blind line, or quarter lines as the posted centerline, the surveyor is not required to provide any additional connections. If the Right of Way is using a road monument that was placed at 90° at the time of the survey, the surveyor is required to move it onto the primary line and show the connection.
19. When a Right of Way is utilizing an existing posted limit and no new monuments are being established, additional connections are not required. All monuments initially established and all monuments defining the extent of the individual parcels of the existing posted limit are required to be found or re-established. All monuments subsequently established on the existing posted limit are required to be searched for and their status shown on the plan. If any new monuments are being established on the existing posted limit, then additional connections are required for these monuments only.

20. New Feature Right of Ways are not to be shown through road parcels or road allowances.
21. New Feature Right of Ways are not required to post the intersection with existing Feature Right of Ways.
22. For Feature Right of Ways which terminate within the interior of a parcel/quarter section, linear and angular measurements must be shown from the terminal monument to the nearest found primary or secondary monuments, with an additional angular tie at the found primary or secondary monument to the terminal points of the Right of Way.
23. A Descriptive Right of Way plan cannot end on another Descriptive Right of Way Plan.
24. The width is to be shown on all Right of Way plans whether the Right of Way is monumented on both sides or not.
25. If a Right of Way plan is required within the limits of a Bareland or Building Condominium Plan, the condo building, or units must be shown as dashed lines or ghosted within the condo plan to adequately show the relationship between the Condominium plan and the Right of Way plan.
26. A descriptive plan for an easement within a Condominium, Bareland, or Combo plan, that is not parallel and adjacent, must be tied to standard iron posts on the exterior boundary of the Condominium.
27. When an Easement Plan is submitted, the source parcel could be either approved/pending or active/titled; the Easement Plan will not distinguish between the two. If an approved/pending plan is presently on the source parcel, the approved/pending plan is to be reflected as opposed to the active/titled plan.

*Condos &  
ROWS*

*Easement  
Clarification*

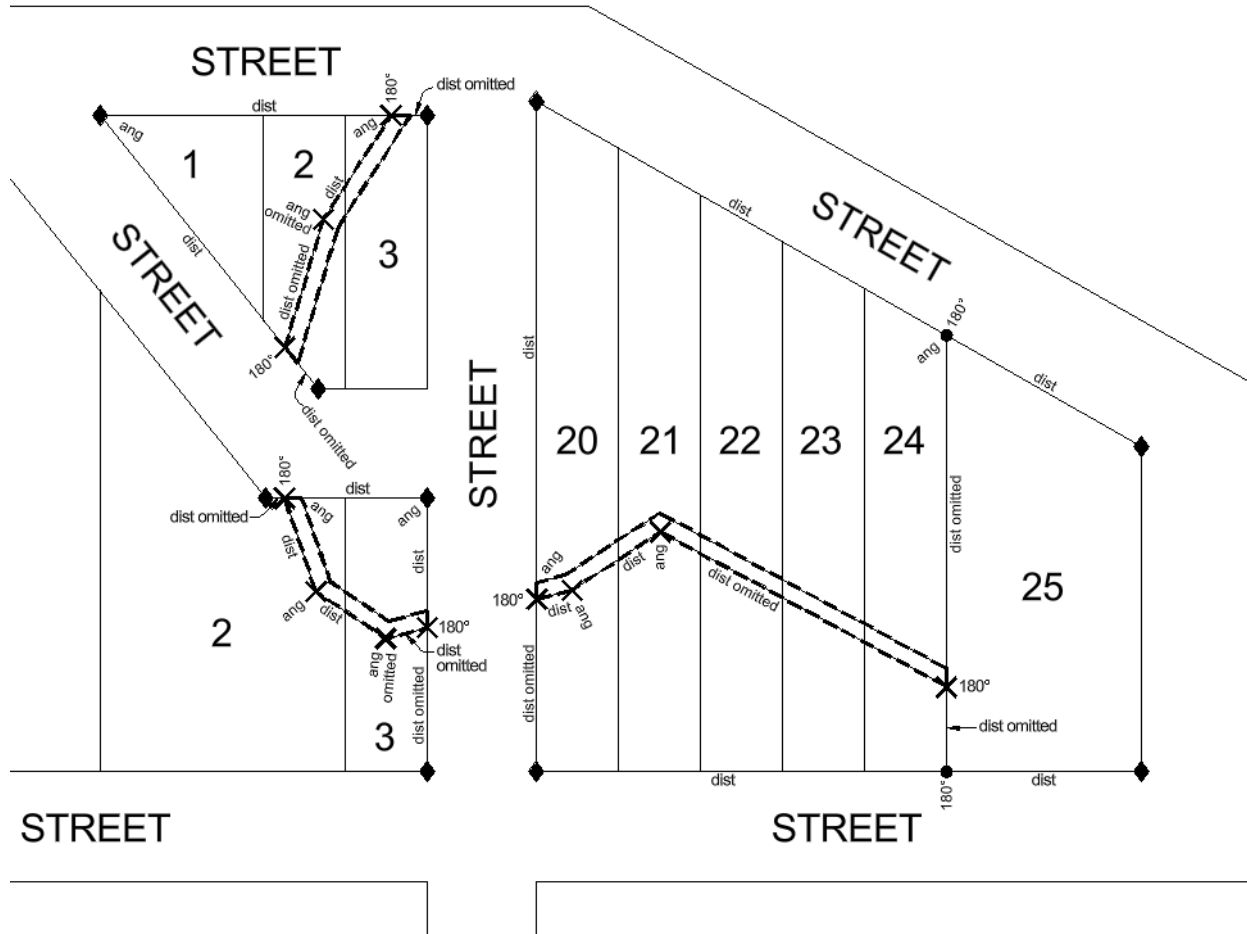

28. The above diagram depicts an urban easement and the necessary monumentation with angular and linear ties required as per Policy GO-04/008. Please note that the angles and distances omitted above is one of several possible options available.

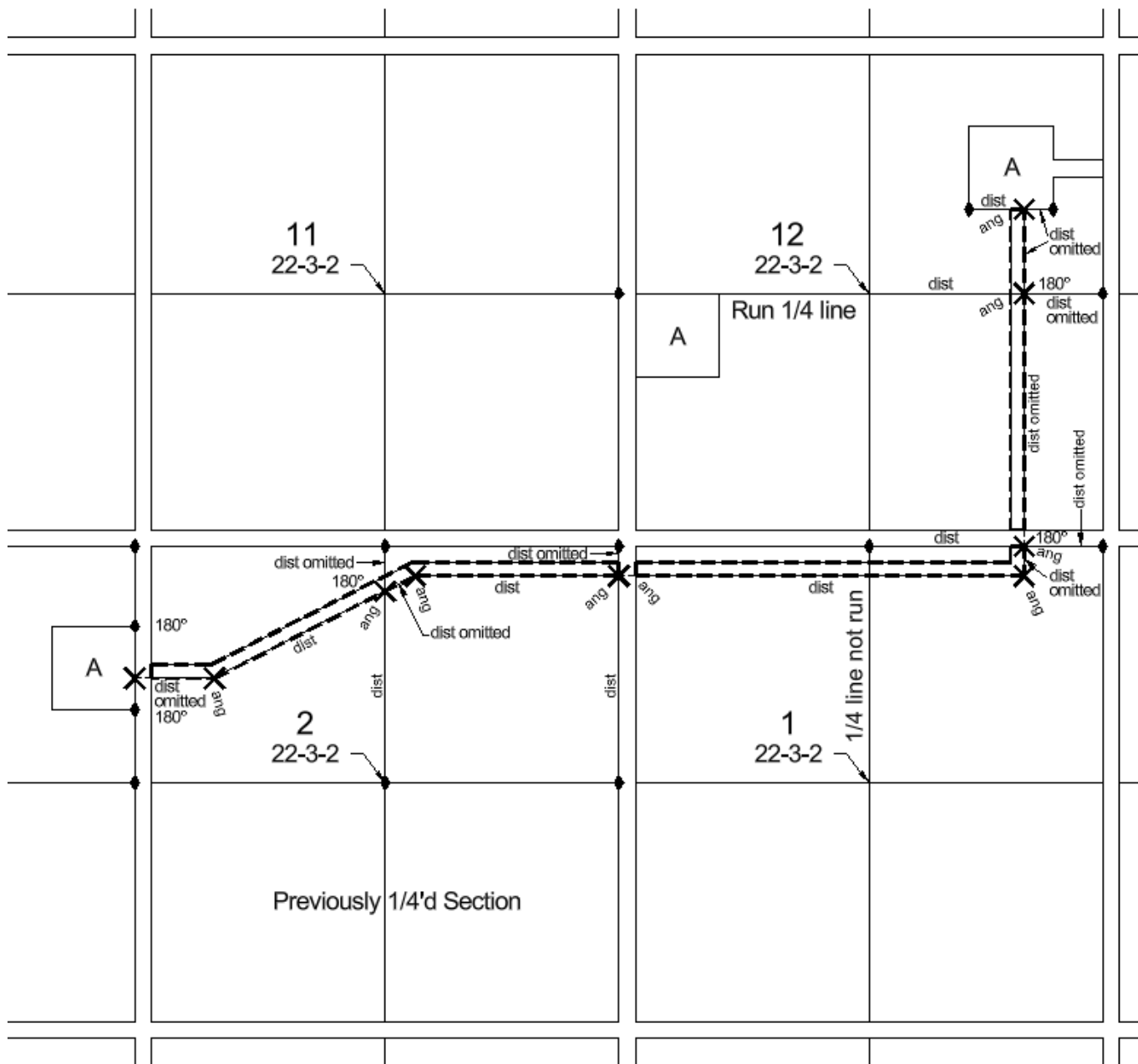

29. The above diagram depicts a rural easement (in this case a flowline), and the necessary monumentation with angular and linear ties required as per Policy GO-04/008. Please note that the angles and distances omitted above is one of several possible options available.

## Power Box Scenarios

### Standard Iron Posts at Block Corners (Proportion Block)

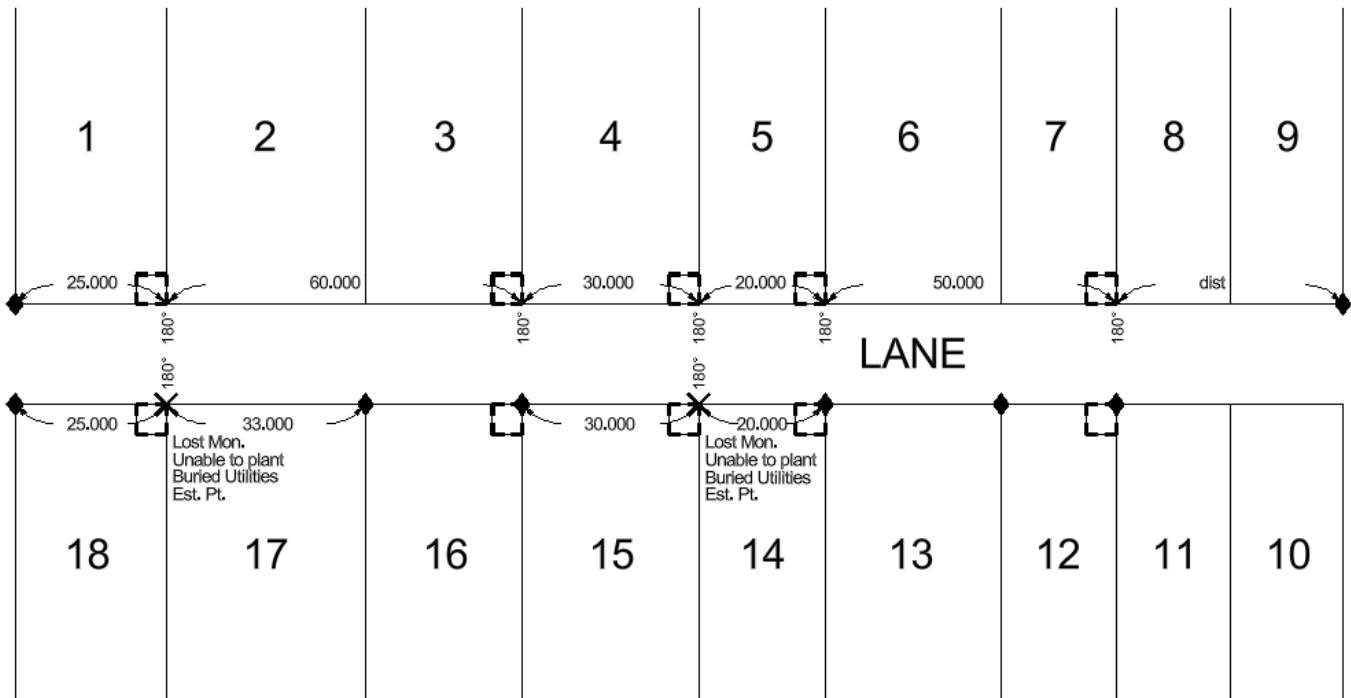

### Standard Iron Posts at Lot Corners

30. As per policy GO-04/008, this is the “Power Box” easement situation. The portion north of the lane depicts the situation where standard monuments have only been placed at the block corners. As this situation is unique, proportioning across the entire block relative to each easement must be present. No distance is to be omitted.

As for the situation south of the lane, this depicts the situation where standard monuments have been placed at each lot corner. The surveyor is required in this situation to work between the closest two standard monuments on either side of each respective easement and proportion in the easement corner relative to the found monuments. No distance is to be omitted.

In all “Power Box” situations, the easement(s) is/are required to be tied to lot or block monumentation on at least a single limit. Additional monumentation can be shown but is optional. Each easement and their corresponding shape will require a detail to depict its length and width.

31. Angles must be shown on new Right of Way limits at all intermediate monuments. In congested areas, a statement may be placed in the legend stating, “New Right of Way limits are straight lines unless otherwise shown” to eliminate the need to show some angles on the new Right of Way limits.

*Angles on ROWs*

32. When a new Right of Way plan is parallel to an existing Right of Way, the bi-sector angle does not need to be shown, nor is the slope tie to the new monument. What needs to be shown are the complementary angles. These angles include the deflection angles on the existing Right of Way, along with the complementary angle shown on the new Right of Way limit. These angles must total 360°.

*Parallel Right of Ways*

33. The plan must only show titled surface and approved feature plans. If measurements are required to be shown from monuments established on a now inactive approved plan, the monument notation will not be affected, but the plan is to be shown as a dashed limit and labelled “plan 76H12501 (inactive approved)”.

*Monuments on Inactive Approved Plans*

34. Easement Instruments or registered interests must not be shown on any plan if it is not represented by a plan within the Land Surveys Directory.

*Interests*

35. A sufficient number of angles must be shown at all intersections to clearly indicate whether or not a deflection exists at the intersection. All linear measurements are required in all directions from the point of intersection.

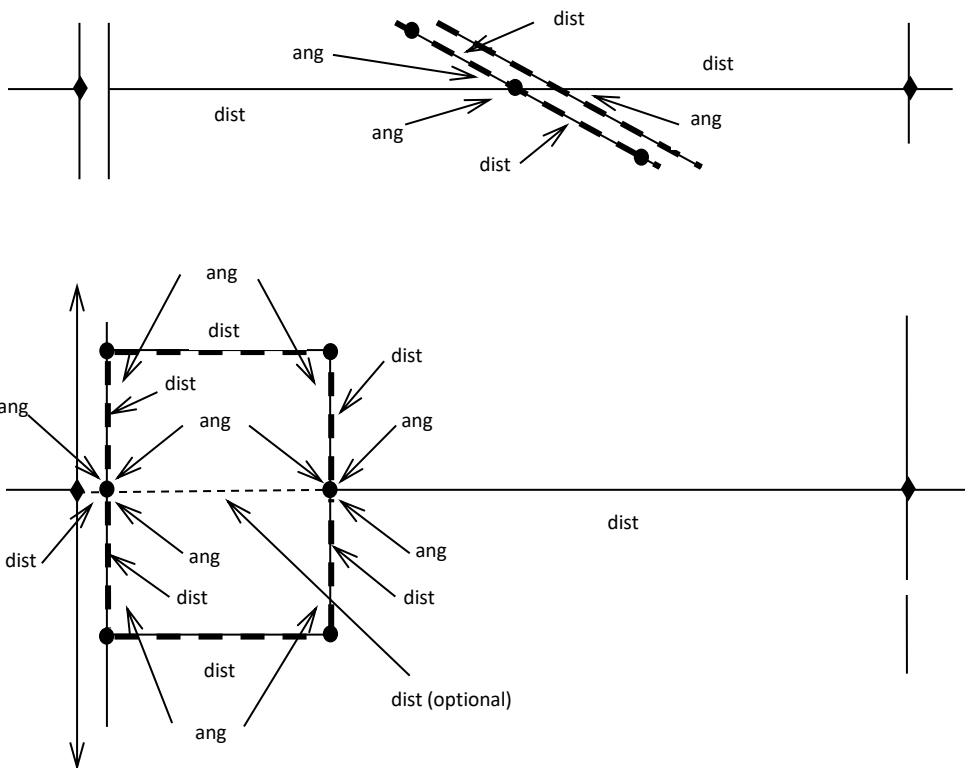

36. Total overall distances must be shown along the surveyed perimeter boundaries of the subdivisions being dealt with.

*Perimeter Distances*

37. Angular and linear measurements are required for each connection to an existing boundary.

38. Angular and linear measurements must be shown for each new boundary. In a lot and block situation, only a single angle is required to be shown to the lot boundary and the supplementary angle is not required if an overall measurement is shown.
39. All primary lines and other surveyed boundaries that no longer exist are not to be redefined and intersected with new secondary surveys; this occurs within new subdivision plans. The plan may show ghosted quarter section lines that are also reflected in the title block. All intersection monuments established on the new plan, based on the above requirement, must be removed before the plan will be approved.
40. Connections at street intersections and road allowances from monuments to new parcels or blocks.

**Example A**

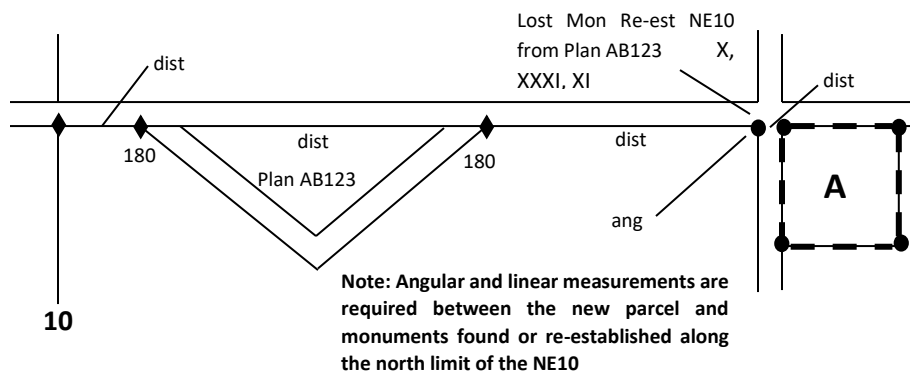

**Example B**

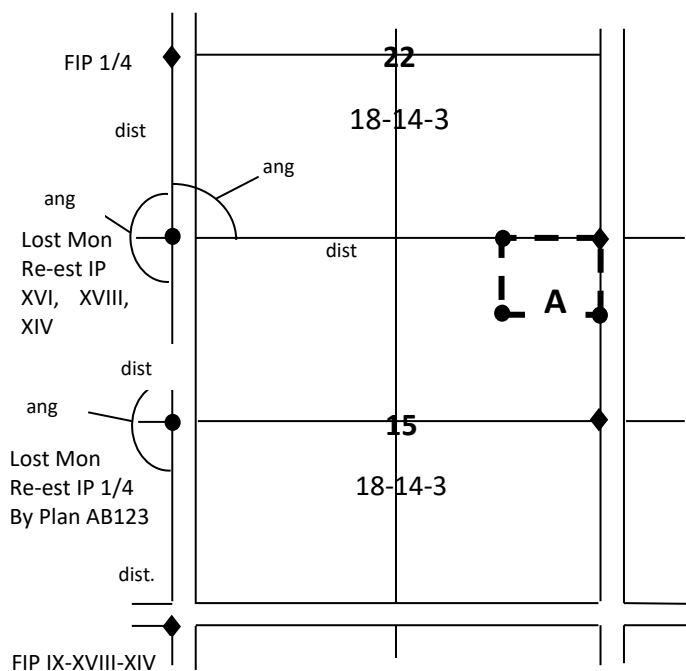



46. When re-establishing block corners, the surveyor is only required to re-establish the block corners required to complete their survey. All standard iron posts on the perimeter of the block required to complete their survey, must be found or re-established as deflections may exist at these positions.

*Block  
Corners*

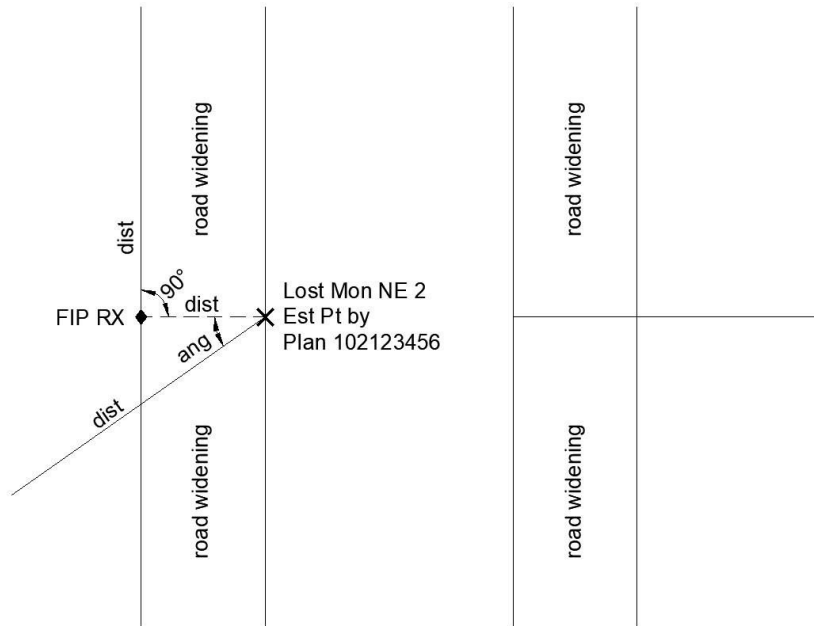

47. When surveying within a block, all found small iron posts at block corners are required to be replaced with a standard iron post. In the situation where the required block corner is lost, it is required to be re-established with a standard iron post. This applies to all new surveys.

A set of continuous lots define the extent of a block portion and its corners; a grid iron subdivision may have two or three block portions with eight or twelve corners respectively with a single block designator. The below block diagram is a single block with two block portions separated by a lane, that has a total of eight corners. The monuments adjacent to the lane are treated in the same manner if they were a block corner.

Additionally, all found small iron posts that are used in the new surveys are required to be replaced or re-established with a standard iron post when they are found at deflection or at the extent of survey. Small iron posts that are found beyond a found deflection or within the extent of the survey are not replaced with a standard iron post. Below, the NW corner lot 2 is not required to be replaced as it is beyond the found deflection at the NW corner lot 3 and the NE corner lot 1 is required to be replaced as it is the extent of the survey as there was no deflection found the NE corner lot 3. If the NE corner lot 1 was not shown on the plan, the NE corner lot 3 would be required to be replaced as it is at the extent of the survey and similarly as the NW corner lot 3, if a deflection was found at the NE corner lot 3 then it is required to be replaced with a standard iron post and it would not be required at the NE corner lot 1. The NE corner lot 9 is not required to be re-established with a standard iron post as there is no deflection at this corner as well the NE corner lot 11 is not required to be replaced with a standard iron post as the block corner at the SE corner lot 12 is used and there also is not a deflection at the NE corner lot 11. Again, if the SE corner lot 12 was not shown, then the NE corner lot 11 is required to be replaced with a standard iron post as it is at the extent of the survey.

The replacing or the re-establishment of a lot corner with a standard iron post is not required on re-establishment plans but required on all other surveys.

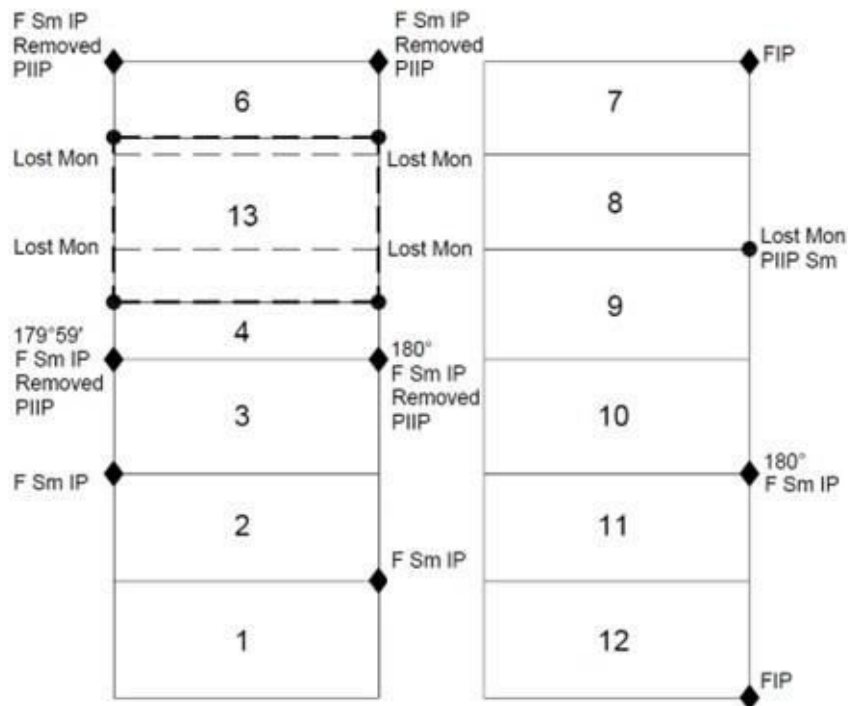

48. When re-establishing a primary monument from a road-widening survey and the primary monument was not found with a road monument placed opposite of the location of the primary, the road monument governs the road limit and not the primary position. In this case, the surveyor could employ one of two methods to re-establish the lost primary: 1) utilize the road plan to re-establish the primary position as long as the road monuments were found within tolerance of the governing plan or 2), utilize township proportion to re-establish the primary position.
49. When a subdivision occurs in a provincial or regional park that is abstract, a note is required to be added to the plan, that “The new parcel(s) created by this plan will remain in the Abstract Directory”, when applicable. A Controller’s Order specific to this, will be issued by the Controller of Surveys to the surveyor who submitted the plan for examination. This order must be submitted as a support document to the plan in order for the plan to be approved. The Controller’s Order is a support document which is also required in the Land Registry submission.
50. When centering a section, all existing secondary surveys do not need to be intersected and monumented.
51. Correction lines must be clearly labeled. Sufficient ties, being perpendicular or angle distance across the correction line are to be shown on the plan when working on both sides of the correction line.
52. The term “Tie Only” is to be used when a surveyor is showing a tie between monuments that are not required to complete their survey. This term can be used between primary monuments, secondary monuments, or combinations thereof. “Tie Only” cannot be stated if the monuments being used are the subject of a re-establishment of a primary or secondary position.

*Subdivisions  
In  
Parks*

*Intersection  
Clarification*

*Correction  
Line*

*Tie Only*

53. For a road allowance to be maintained at a constant width, the proper deflection point on the unmonumented limit of the road allowance opposite a primary corner must be established. This is to be taken into consideration when surveying from a primary monument where a deflection is found in the road allowance, and the section or quarter section line is surveyed across the road allowance to the primary corner on the opposite side of the section. A 5-sided quarter section may occur on both a north south and east west road allowances as well at the intersection of two road allowances in the south east corner of the south east quarter and in the north west corner of the north west quarter, but not in the north east corner of the north east quarter or in the south west corner of the south west quarter.

In the case of a 5-sided quarter, a detail must be shown on the plan of survey indicating the distance between the intersection point and the deflection point. If the distance is 0.5 metres or more, a monument must also be established at the deflection point.

In the detail shown on the following page, it shows all the distances and angles required to be shown. Required distances and angles include, between the primary monument, the intersection point on the quarter section line with the unmonumented limit of the road allowance, and the deflection point in the unmonumented limit of the road allowance.

In the example below, where the survey does not require the surveyor to locate the NE9 in order to determine if a deflection exists, then this requirement will be waived. However, the surveyor can complete additional work to define the deflection and comply with the above requirement, if they choose to do so. Using the example below as reference, if the new parcel is in the NW15, and the deflection is outside the new parcel, a detail is still required to be shown, and the 0.5 metre requirement would still apply.

Example:

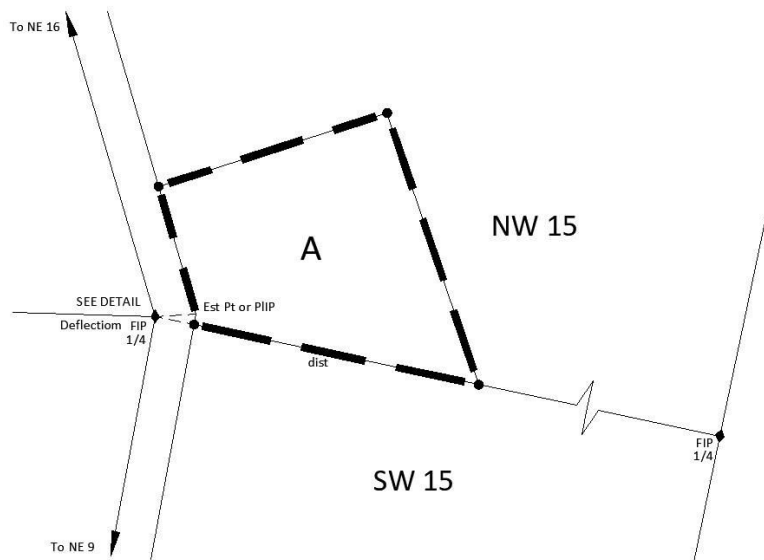

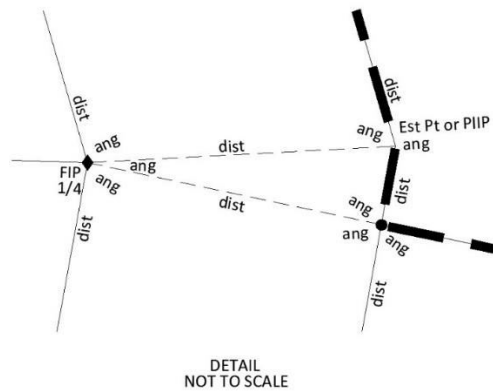

54. In situations where there is a new plan, particularly a parcel, IR Boundary, or road, adjacent to a road allowance, the deflection in the unmonumented limit is to be handled and reflected as defined above. This includes the situation when the deflection is not within the new surveyed parcel as well. In the situation where there is no new plan adjacent, but there is tie line or re-establishment that notes there is a 5-sided quarter, the surveyor may reflect this on the plan. Where the surveyor is posting the unmonumented limit of the road allowance, it will be required to be handled and reflected as defined above.